

BENETTI
stone philosophy





Stone supports and protects



Benetti Stone Philosophy

Il nuovo brand Benetti Stone Philosophy nasce nel 2008, dall'esperienza di Studio Biemme 2 e dalle ricerche volte alla sperimentazione di soluzioni innovative sia dal punto di vista estetico che dal punto di vista qualitativo, combinando lavorazione artigianale e moderne tecnologie.

L'art direction dell'architetto Fabio Rotella mira a sintetizzare decoro, tradizione, innovazione e qualità verso una nuova direzione, confrontandosi con le tendenze emergenti nel design e nell'architettura, per soluzioni che possano soddisfare i progetti più complessi.

Il materiale principe è la pietra che, grazie al know-how tecnico di elevata qualità ereditato da Studio Biemme 2, viene lavorata per creare superfici intagliate, levigate, grezze o decorate, realizzate come veri e propri pezzi unici, per trasmettere l'emozione del naturale ed esaltare il valore della materia come tale.

La padronanza e la perizia artigianale, l'approfondita conoscenza della materia e le tecniche di lavorazione permettono a Benetti di non essere vincolato da misure standard ma di operare su formati liberi, ricercando la migliore soluzione per una realizzazione finale ottimale ed aderente ad ogni esigenza.

Le diverse collezioni prodotte propongono soluzioni per pavimentazioni e rivestimenti di pregio e nuove raffinate proposte d'arredo dedicate all'architettura.

Benetti Stone Philosophy

Benetti Stone Philosophy new collection was born in 2008 from Studio Biemme 2 knowledge and researches on aesthetics and quality, combining handcraft tradition and new manufacturing technologies.

Architect Fabio Rotella, Benetti Stone Philosophy art director, aims at merging decoration, tradition, novelty and quality keeping up with the latest architectural and design trends to work out the most complex projects.

Stone is the main and basic material that, thanks to the high quality technical know-how inherited from Studio Biemme 2, is carved, honed, decorated to create unique pieces, to convey natural emotion and enhance the value of the material itself.

Manufacturing skills command, deep material and working techniques knowledge make Benetti line free from standard sizes and gives it the chance to work on free lay-outs, looking for the best final solution for any need.

Benetti Stone Philosophy's different collections suggest precious solutions for floor and covering and new sophisticated interior design proposals dedicated to architecture.



La Pietra

L'uomo da sempre trasforma e manipola la materia realizzando infinite varianti di opere dedite a funzioni diverse. Utilizzando e trasformando le risorse del pianeta, l'uomo ne ha abusato all'infinito. Oggi i materiali naturali, la pietra come il legno, devono essere considerati risorse preziose da tutelare e da usare con consapevolezza. La pietra rappresenta una costante nello sviluppo culturale dell'essere umano, il suo utilizzo: come utensile, come superficie da dipingere, come elemento costruttivo o decorativo, la posiziona tra i materiali più sfruttati al mondo. È da questa idea che nasce la genesi di "Benetti stone philosophy" una collezione di lastre in pietra lavorata, superfici realizzate come veri e propri pezzi unici, nati da monoliti pregiati per trasmettere l'emozione del naturale; esaltare il valore della materia come tale, anche se trasformata in opera piana generando superfici intagliate, lisciate, grezze o decorate. Interpretazioni di paesaggi onirici, come in un susseguirsi di idee che diventano desideri da inseguire ed infine da possedere. La libertà dei formati della nuova collezione dà il senso dell'unicità, le lavorazioni trasmettono il senso della poeticità del materiale per una serie completa dedicata, delicata ma nel contempo fortemente caratterizzata.

"La Fabbrica delle energie nascoste"

Benetti è una famiglia di artigiani dedita allo sviluppo di una passione, la lavorazione della pietra, con anni di esperienze e di vita dedicata alla ricerca di una identità aziendale che interpreti il suo vissuto. La mia collaborazione come Art Director dell' Azienda nasce da un incontro casuale, ho scoperto un gruppo di persone sensibili, piene di energia, disponibili a mettersi in gioco, con sogni nuovi da inseguire.



The Stone

Man has always transformed and worked matter, creating endless variations of all kinds of items. His use and transformation of the planet's resources has become an exploitation.

As a consequence, nowadays natural materials such as stone and wood must be considered precious and therefore they are to be protected and utilized in full awareness. Stone represents a standard feature in human cultural development: having been used as a tool, as a painting base, as a structural or decorative element makes it one of the most commonly used materials worldwide. "Benetti stone philosophy" is originated precisely from this idea. It is a collection of carved stone slabs, conceived as one-off pieces and taken from precious monoliths to convey naturalness, enhancing the matter's own value - even if now it is a flat item - through carved, polished, raw or decorated surfaces. These are interpretations of oniric landscapes, like a stream of ideas that turn into wishes which one at first follows and then at last grasps. The new collection's variety of sizes transmits uniqueness, while the finishings recall the material's own poeticness, composing a complete series where sophistication coexists with strong personality.

"The Factory of hidden energies"

The Benettis are artisans who focus on their passion, working stone, and whose own huge experience and life-long research is reflected in the company's identity. My art direction on "Benetti stone philosophy" represents my interpretation of their know-how. Thanks to an accidental business meeting I discovered a team of people that are sensitive, energetic, willing to take risks and to chase new dreams that are very similar to mine.



Federico Benetti





PARETE DEI FUOCHI

ORION

SPECCHIO

GIARDINO VERTICALE ORGANICO

CRISTALLO

BOSCO DI PIETRA

PARETE DECO

LUCE

ALGUA

VASCA





INDICE | INDEX



17 TEXTURES



119 LACES



141 NEW CLIFF | LIGHT CLIFF | CLIFF



169 MOSAICOCONTEMPORANEO



251 ORION



295 MIDA&TONE



343 STONES



355 SKINS



359 AQUAM



405 MONOLIGHT



TEXTURES

Tartan
Barrè
Raphia
Juta
Free



TEXTURES | Tartan

Superfici rigide dall'aspetto morbido, la pietra che diviene tessuto da utilizzare come rivestimento, un tessuto che si trasforma e regala sorprendenti soluzioni. Tartan è una collezione di grafi realizzati con originali decori ispirati al mondo del tessile e della moda. I disegni creati dall'insieme ripetitivo di segni a schema continuo formando una grafica a trama.

Stiff surfaces with soft looks: stone becomes almost fabric, a fabric which can be used for coverings, transforms itself and provides surprising solutions. Tartan is a collection presenting peculiar decorative graph-like motifs inspired by textiles and fashion: the continuous repetition of single signs creates weave-like patterns.





Scent of scottish tartans

TARTAN T01 YUNA DARK







TARTAN T01 NERO

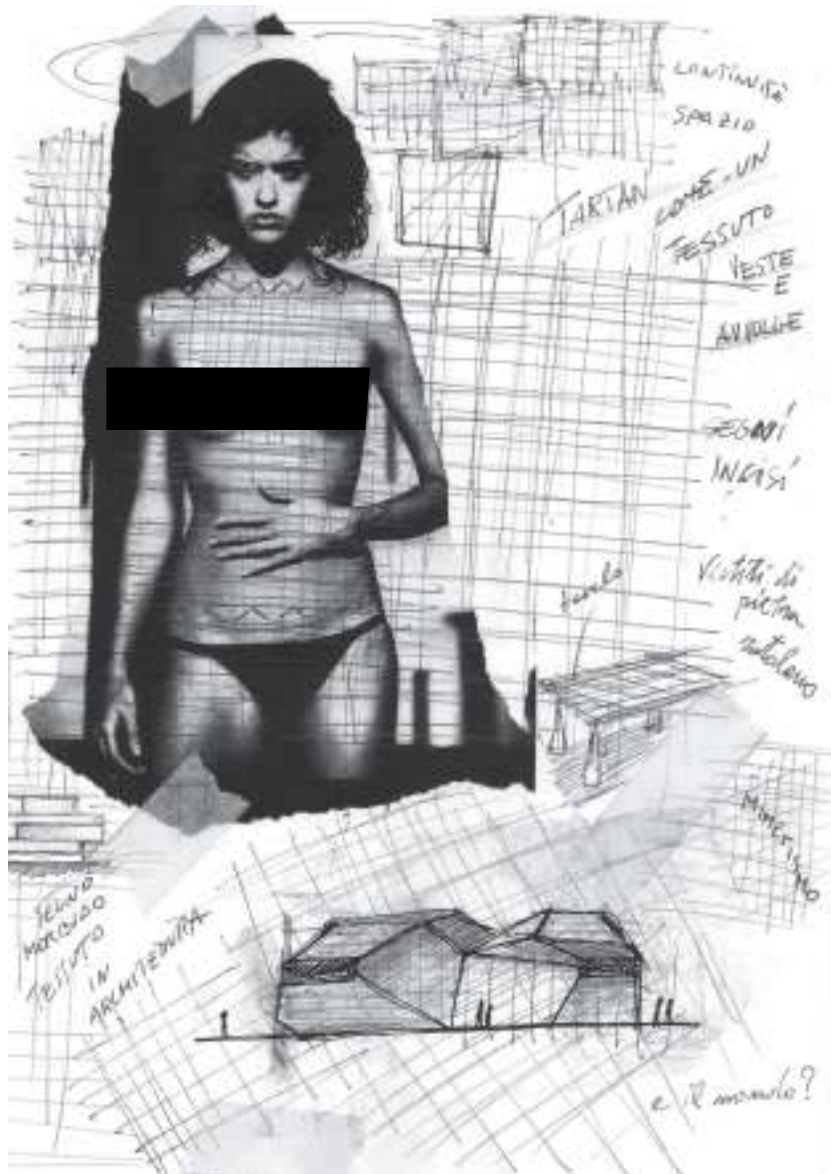

Tartan: almost “alive” carved lines for sensitive surfaces



TARTAN T01 YUNA DARK





TARTAN T01 YUNA DARK | TARTAN T01 SOPHIA BEIGE



32

TARTAN T01 YUNA DARK MATT
TARTAN T01 YUNA DARK CUT



TARTAN T01 YUNA DARK | TARTAN T01 SOPHIA BEIGE





34

Stolen from a child

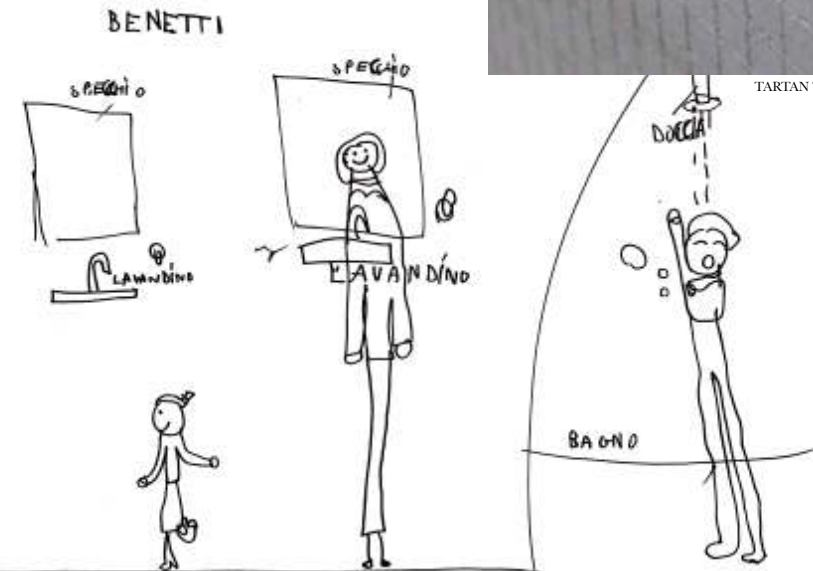

TARTAN T04 YUNA DARK CUT



TARKAN T04 YUNA DARK CUT

TARTAN T04 YUNA DARK

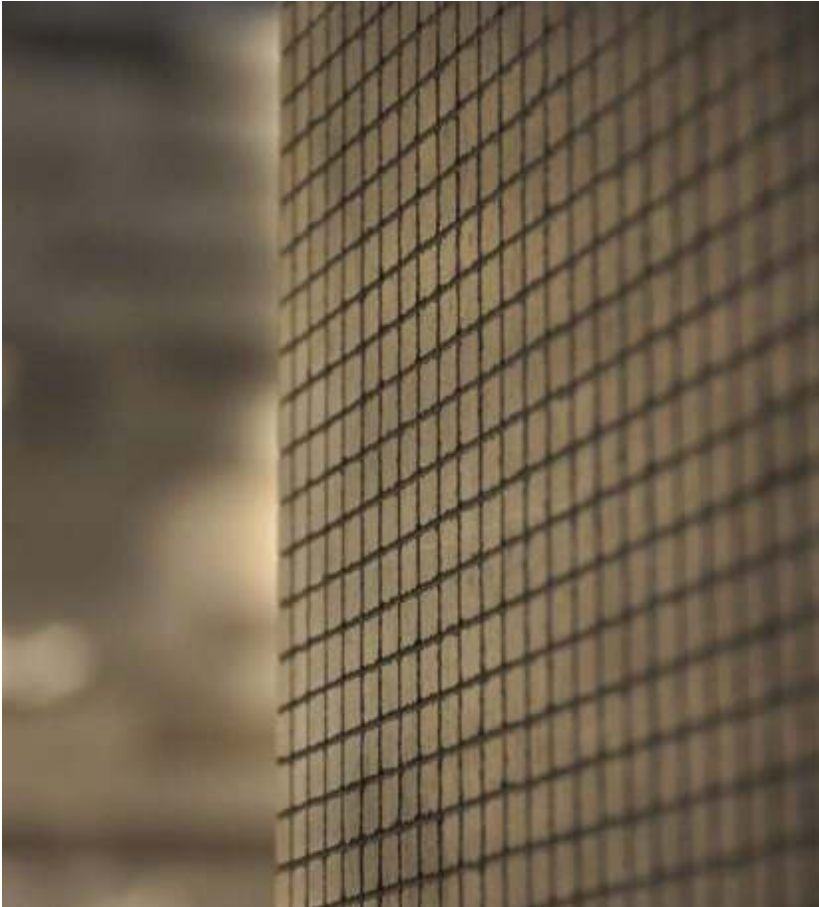

TARTAN T04 YUNA DARK MATT
TARTAN T04 YUNA DARK CUT



TEXTURES | Tartan

Tartan T01

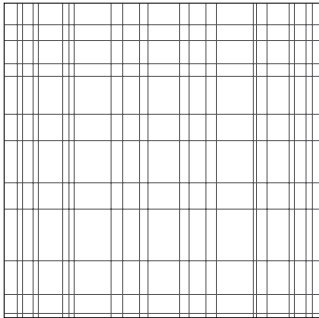

Tartan T02

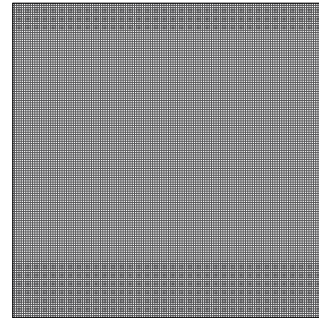

Tartan T04

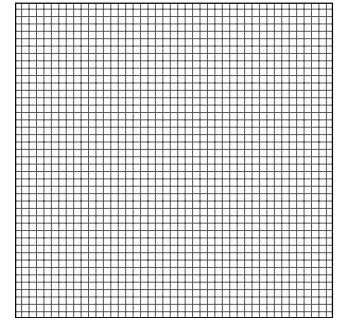

TEXTURES | Tartan T01



YUNA DARK

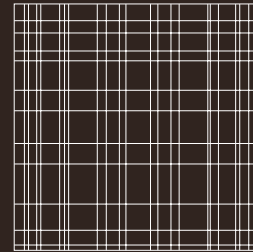

Sizes
29.6x29.6x1cm

Formati speciali su richiesta.
Special sizes on request.

Tartan T01



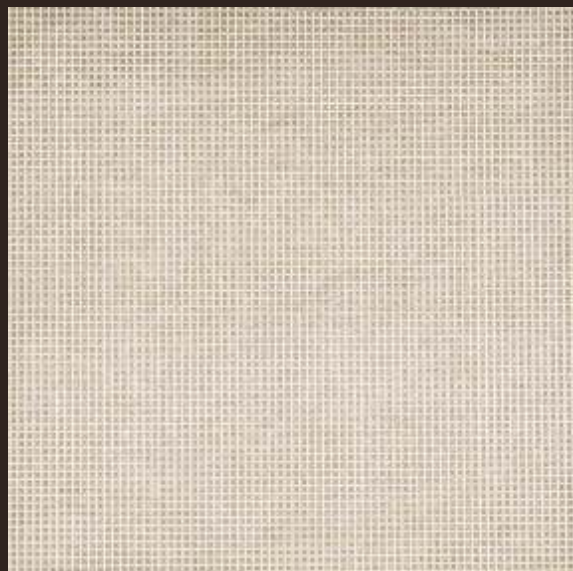

YUNA DARK

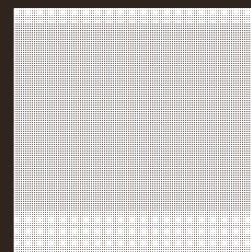

Sizes
29.6x29.6x1cm

Formati speciali su richiesta.
Special sizes on request.

Tartan T02



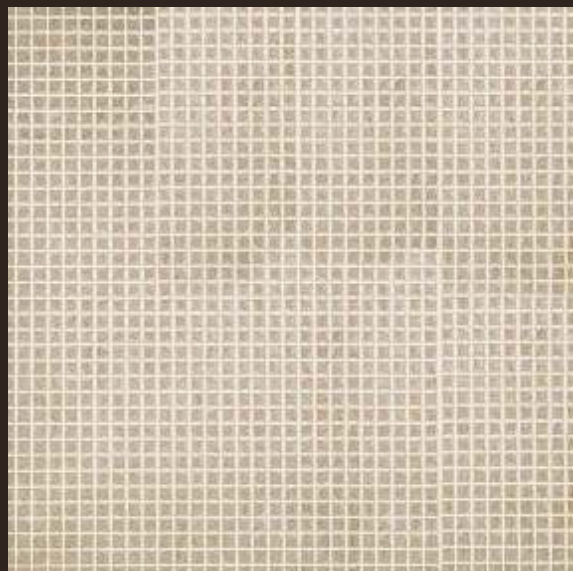

YUNA DARK

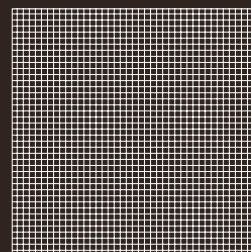

Sizes
29.8x29.8x1cm
29.8x59.8x1cm

Formati speciali su richiesta.
Special sizes on request.

Tartan T04





TEXTURES | Barrè

Orizzonti ripetuti all'infinito, linee parallele scalfite nella pietra che svelando effetti visivi rendono la pietra come un paesaggio sensoriale da visitare e sfiorare. La collezione Barrè è composta da decori fresati realizzati con diversi gradi di intervento su superfici di pregio.

Endlessly repeated horizons, carved parallel lines that create visual effects and turn stone into a sensory landscape to be visited and touched. Barrè is a collection that presents a variety of milled motifs performed on different levels on precious surfaces.





50

BARRÈ SPECIAL YUNA DARK



BARRÉ SPECIAL YUNA DARK



BARRÉ SPECIAL YUNA DARK
BARRÉ B05 YUNA DARK



BARRÉ B05 YUNA DARK

Parallel lines,

endless horizons

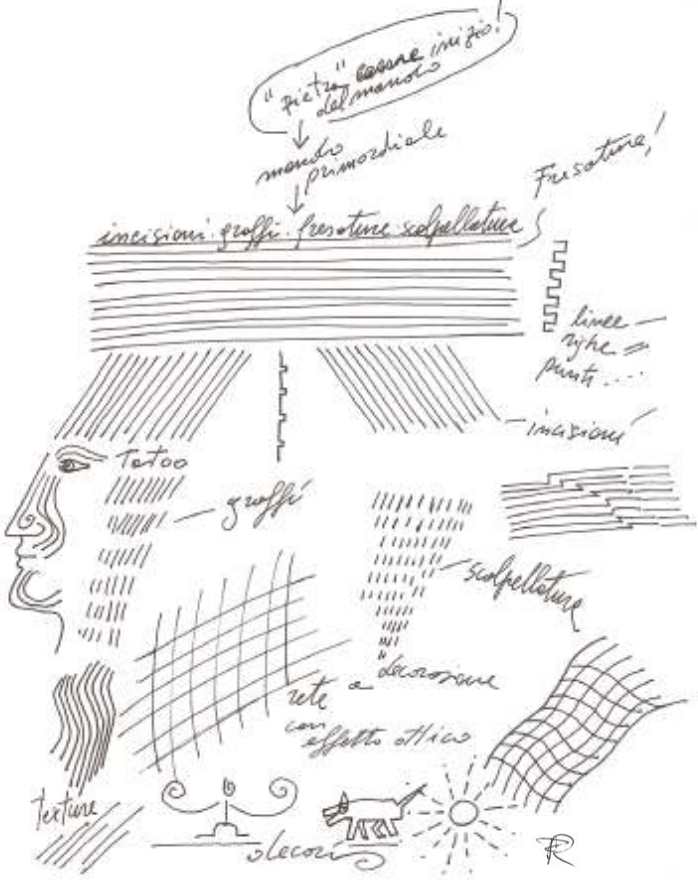

54





BARRÉ B02 NERO MATT | BARRÉ B02 NERO CUT



BARRÉ B04 YUNA DARK

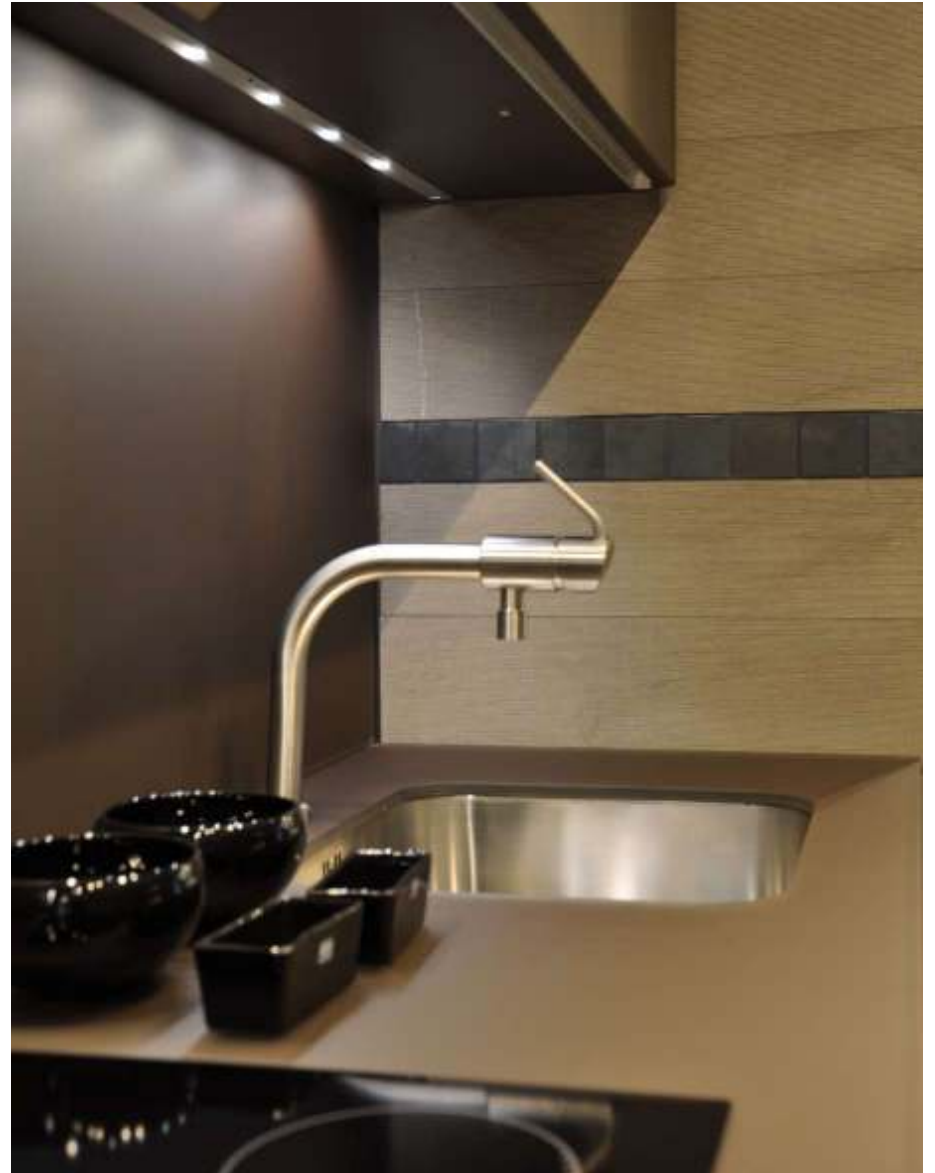



*The different tactile
and visual effects in this
series are almost vocal
and recall guitar
playing music*



TEXTURES | Barrè

Barrè B01

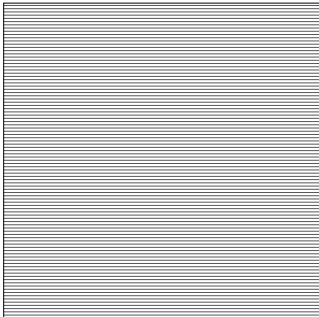

Barrè B02

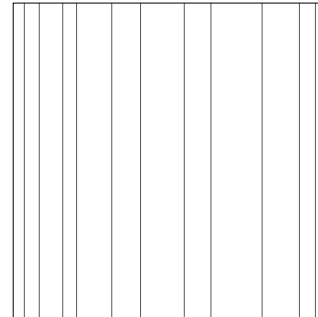

Barrè B04



Barrè B05

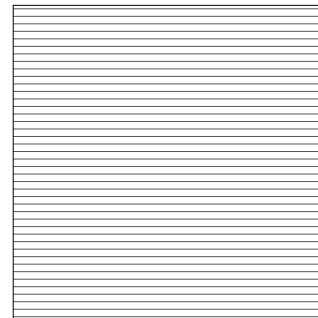

Barrè B07

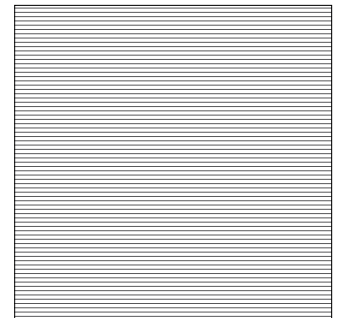

TEXTURES | Barrè

B01



YUNA DARK



Sizes
29.8x29.8x1cm
29.8x59.8x1cm

Formati speciali su richiesta.
Special sizes on request.

Barrè B01



TEXTURES | Barrè

B02



NERO CUT

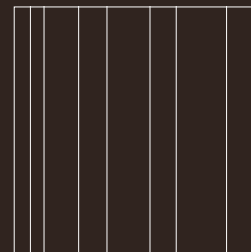

Sizes
29.8x29.8x1cm
29.8x59.8x1cm

Formati speciali su richiesta.
Special sizes on request.

Barrè

B02





CREMA STONE



Sizes
29.8x29.8x1cm
29.8x59.8x1cm

Formati speciali su richiesta.
Special sizes on request.

Barrè B04



TEXTURES | Barrè

B05



NERO

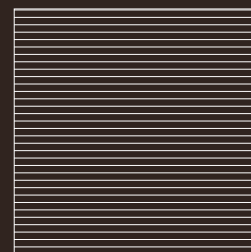

Sizes
29.8x29.8x1cm
29.8x59.8x1cm

Formati speciali su richiesta.
Special sizes on request.

Barrè B05



TEXTURES | Barrè

B07

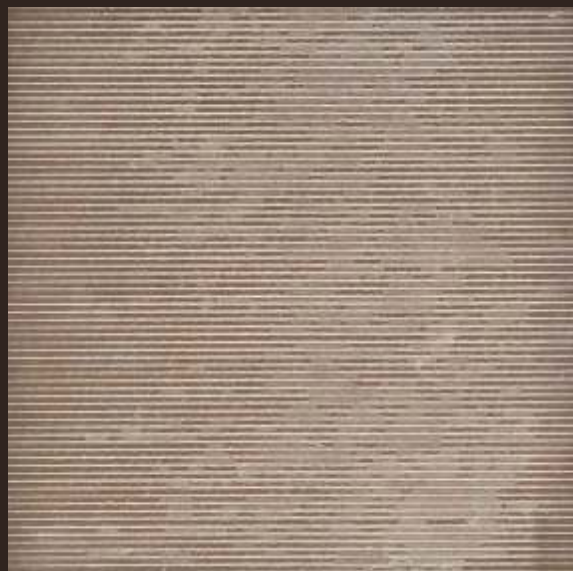

ARDESIA BORDEAUX



Sizes
29.8x29.8x1cm
29.8x59.8x1cm

Formati speciali su richiesta.
Special sizes on request.

Barrè B07





TEXTURES | Raphia

Linee forti e dinamiche che segnano e disegnano ampie lastre di pietra. Un segno energico e distintivo, che si ispira agli intrecci delle fibre naturali.

Strong and dynamic lines designing large stone fibres. An energetic and distinctive sign, inspired by the patterns of natural fibers.



Strenght and
lightness
coming from
nature





The Old Fashion Café Milano
RAPHA CREMASTONE



An energetic and distinctive sign



TEXTURES | Raphia

R01



YUNA DARK



Sizes
29.8x59.8x1cm

Formati speciali su richiesta.
Special sizes on request.

Raphia R01



TEXTURES | Juta

Superfici tridimensionali solcate da segni orizzontali dolci e convessi. Una superficie morbida che evoca ricordi e profumi densi e sensuali.

Three-dimensional surfaces are crossed by smooth and convex horizontal signs. A soft surface evoking memories, dense and sensual fragrances.







ARDESIA NERA

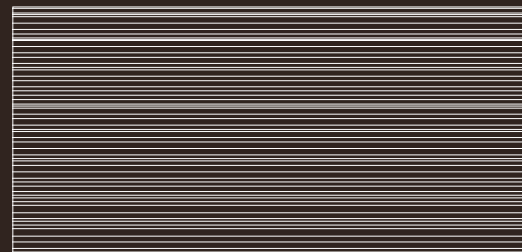

Sizes
29.8x59.8x1cm

Formati speciali su richiesta.
Special sizes on request.

Juta J01



TEXTURES | Free

Libertà nella decorazione, disegni che attingono nella memoria, segni provenienti dalle diverse arti decorative per esprimere nella semplicità l'unicità delle lastre in pietra. Collezione di superfici disegnate da un percorso di contaminazione tra i diversi mondi delle arti applicate.

Freedom in decoration: designs of traditional origins and motifs taken from different decorative arts to express through simplicity the uniqueness of the stone slabs and to express a creative contamination between the worlds of applied arts.





Open minds,

rulebreaking compositions



FREE F04 YUNA DARK





FREE F06 KAISER BROWN



Free compositions for geometrical yet poetical patterns



100

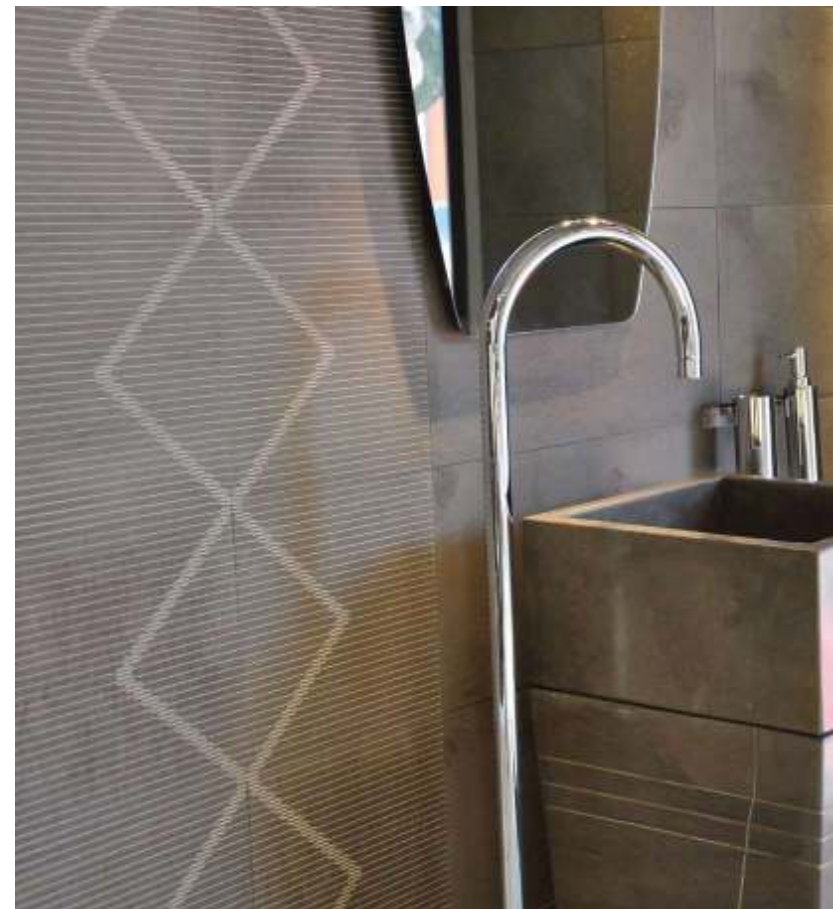

FREE F03 YUNA DARK



FREE F03 ARDESIA BORDEAUX



103

FREE F03 ARDESIA BORDEAUX



FREE F01 ARDESIA NERA

FREE F05 ARDESIA NERA



FREE F04 YUNA DARK



TEXTURES | Free

Free F01

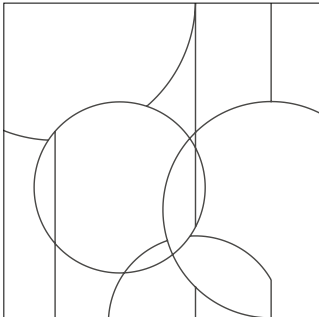

Free F03

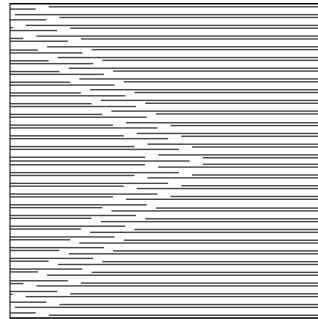

Free F04

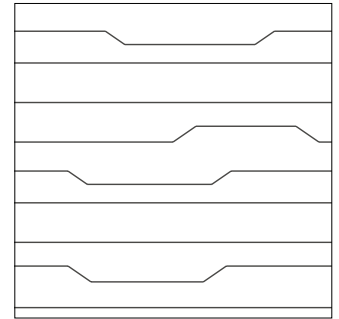

Free F05

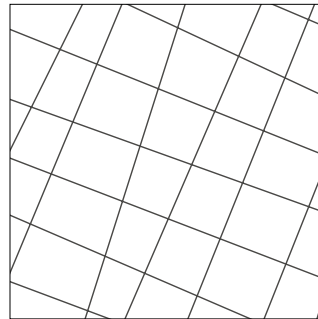

Free F06

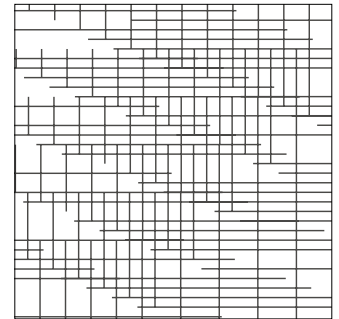

TEXTURES | Free

F01



ARDESIA NERA

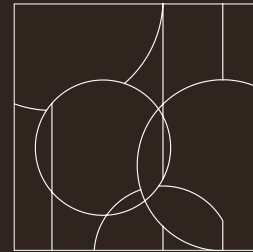

Sizes
29.8x29.8x1cm

Formati speciali su richiesta.
Special sizes on request.

Free

F01



TEXTURES | Free

F03

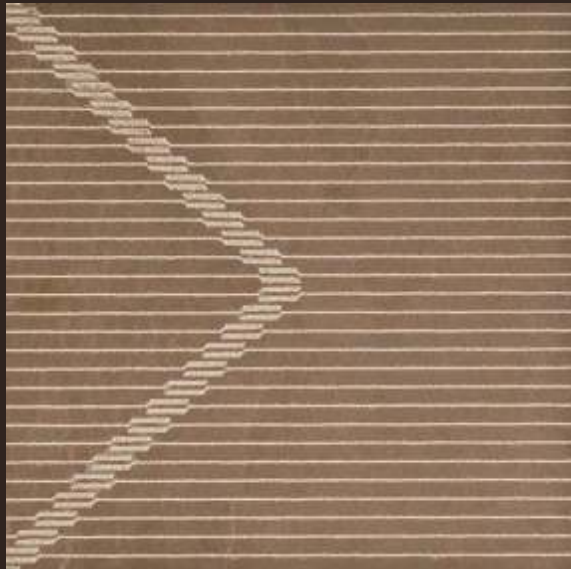

ARDESIA BORDEAUX



Sizes
29.8x29.8x1cm

Formati speciali su richiesta.
Special sizes on request.

Free

F03



TEXTURES | Free

F04



YUNA DARK

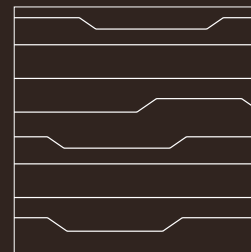

Sizes
29.8x29.8x1cm

Formati speciali su richiesta.
Special sizes on request.

Free F04



TEXTURES | Free

F05



ARDESIA NERA

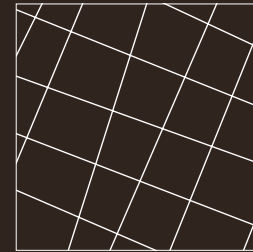

Sizes
29.8x29.8x1cm

Formati speciali su richiesta.
Special sizes on request.

Free

F05



TEXTURES | Free

F06

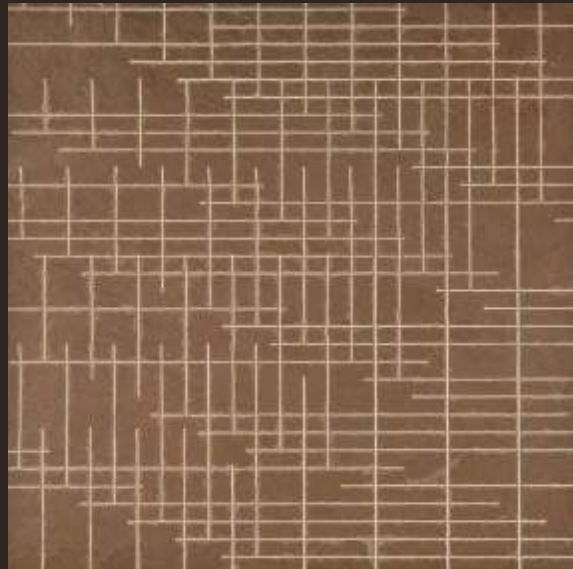

ARDESIA BORDEAUX

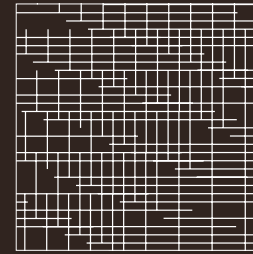

Sizes
29.8x29.8x1cm

Formati speciali su richiesta.
Special sizes on request.

Free

F06





LACES

Rococò
Arzigogolo
Verba Manent
Ramages



LACES |

Laces interpreta con libertà e sintesi contemporanea stili decorativi che ripropongono le stampe di broccati e ramage.
“Le parole più durature si scrivono sulla pietra”, è così che la pietra incisa, torna ad essere un libro per i racconti; poesie e pensieri vibrano sulla superficie e diventano mementi, attimi e parole da ricordare in maniera indelebile.

Laces interprets with freedom and contemporary sense other decorative styles reintroducing brocade prints and ramage. “The most lasting words are written on the stone”. Carved stone thus results again being a narrative book; poetry and thoughts pulse on the surface and become mementoes, instants and words to be recorded as unforgettable moments.





Lasting precious needleworks

LACES KAISER BROWN



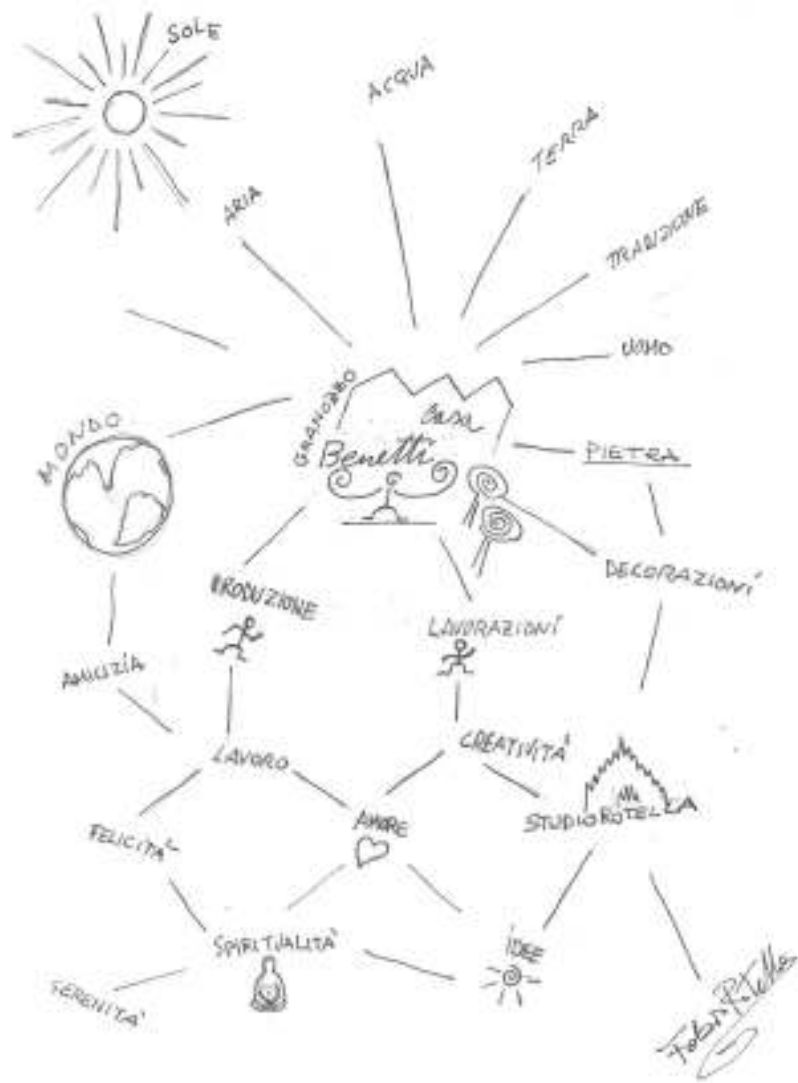



126

LACES ARZIGOGOLO SINGOLO | DOPPIO KAISER BROWN





LACES |

Rococò



Arzigogolo

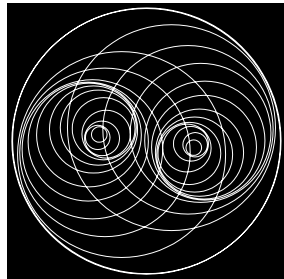
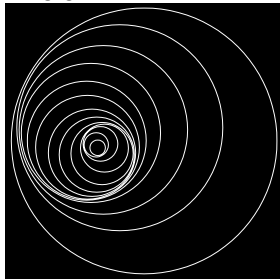

Verba Manent

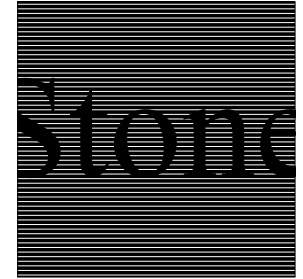

Ramages

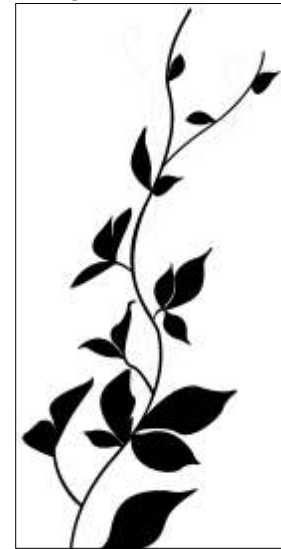



LACES | Rococò

Fondo matt



Decoro matt



YUNA DARK



LACES | Arzigogolo

Singolo

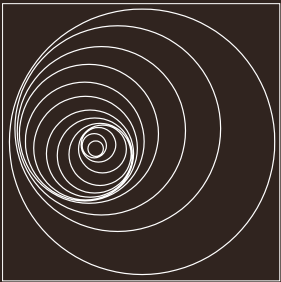

Doppio

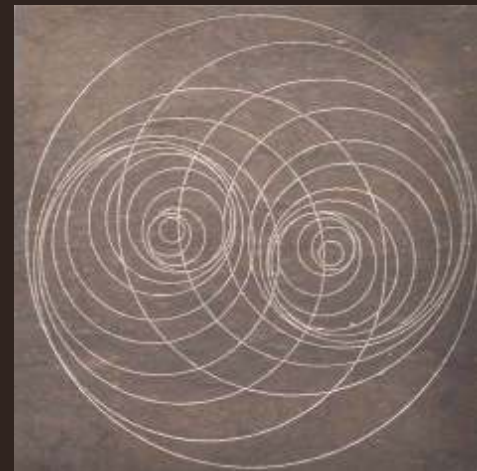
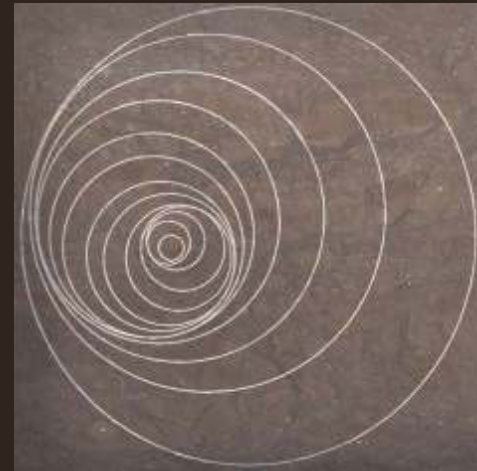
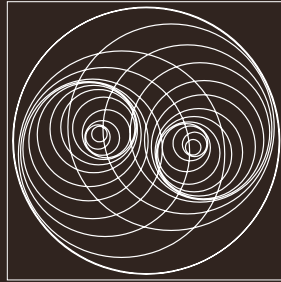

KAISER BROWN



LACES | Verba Manent

Light

Stone

Regular

Stone

Bold

Stone

Stone

Stone

Stone

YUNA DARK



LACES | Ramages

Decoro matt



Fondo matt



KAISER BROWN



LACES | Ramages

Doppio



KAISER BROWN

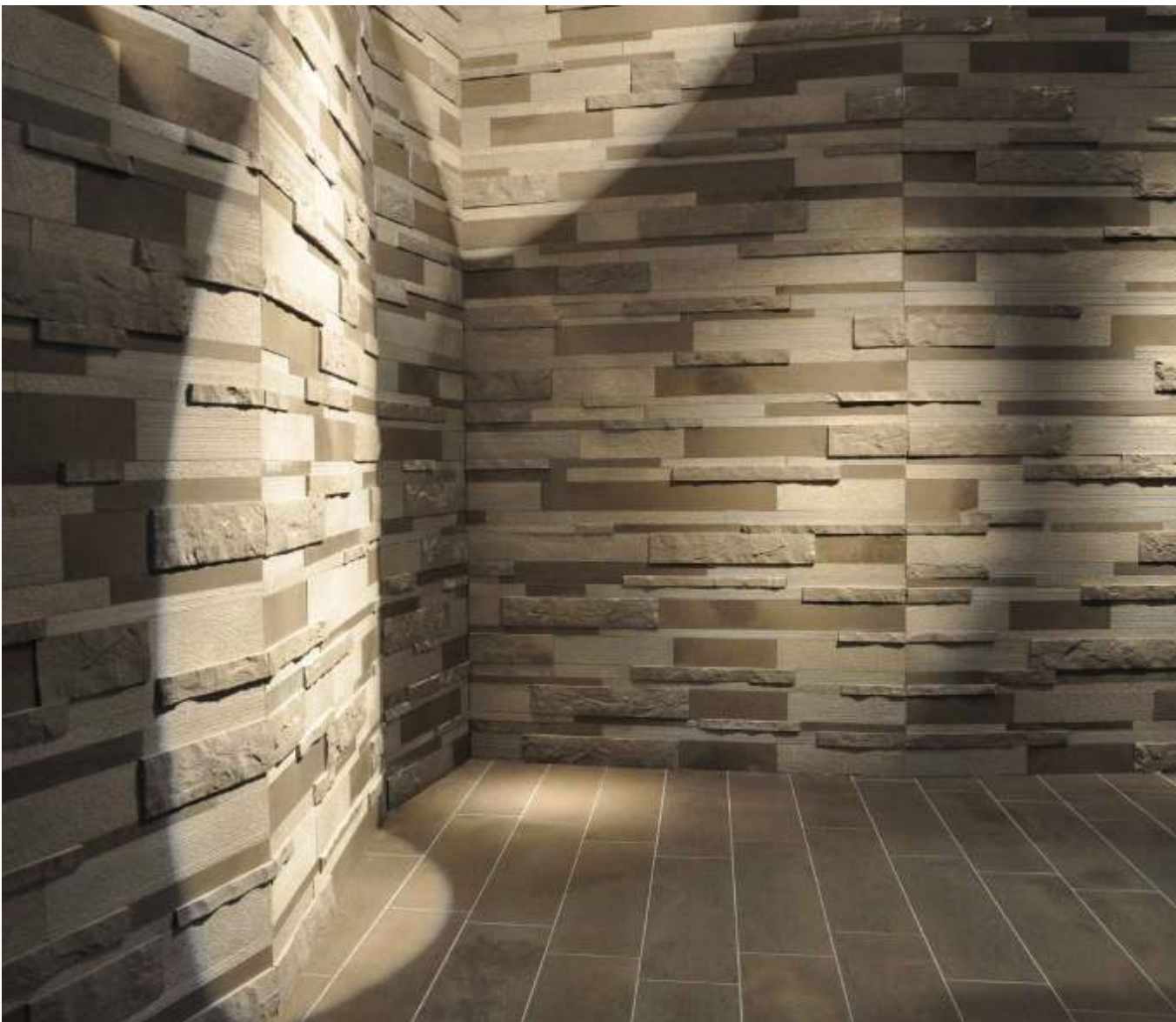

NEW CLIFF
LIGHT CLIFF
CLIFF



| NEW CLIFF | LIGHT CLIFF | CLIFF

Solo pietre naturali per una visione tridimensionale nuova della materia, che permette di giocare sull'eleganza delle cromie proposte e su formati duttili, che lasciano spazio alla creatività del progettista d'interni, coniugando la lavorazione artigianale con la moderna tecnologia per arrivare a un prodotto su misura, d'atelier.

Only natural stones for a new three-dimensional view on matter that enhances the elegance of the colourings and the versatility of the sizes, thus allowing the interior designer maximum freedom. This is a custom-made, almost atelier product, the result of the merging of handcraft manufacturing and contemporary technologies.

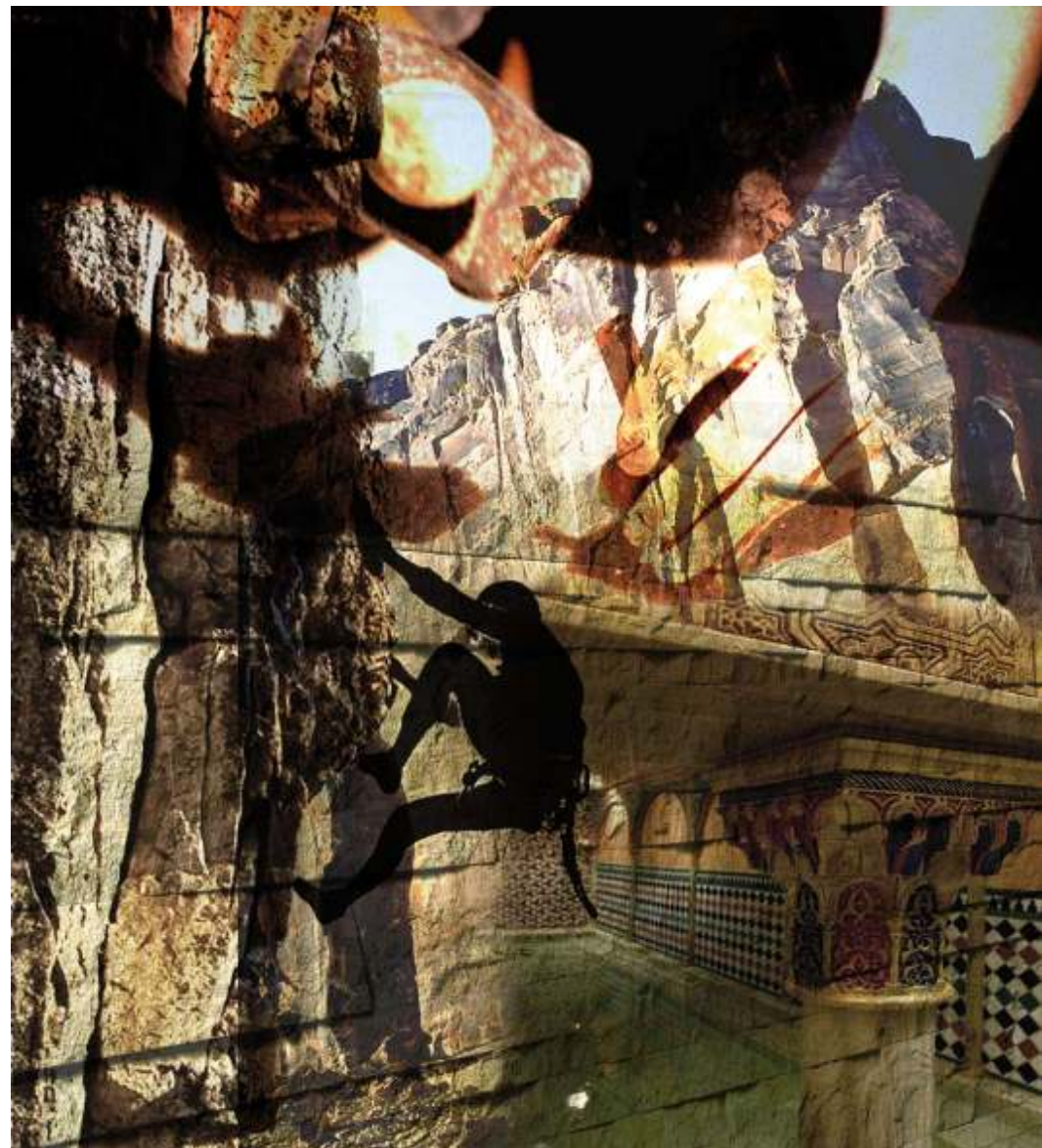

NEW CLIFF YUNA DARK





The Old Fashion Café Milano
SPECIAL CLIFF CREMASTONE

NEW CLIFF



CREMASTONE



YUNA DARK

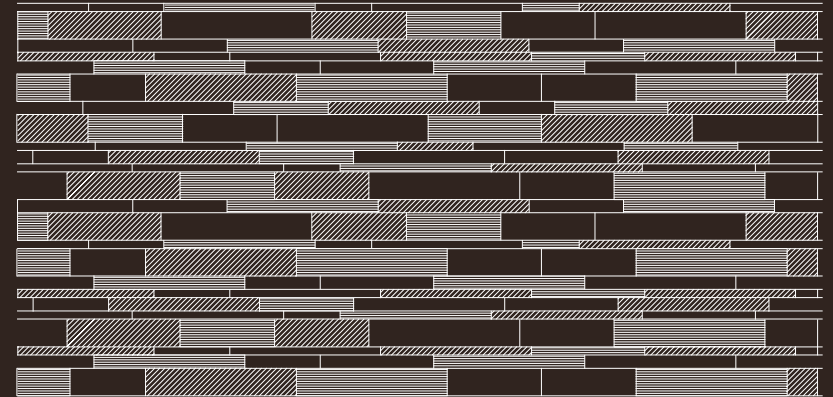

12.9cm

H=12.9cm
fila 1 H=7.3 (56.6%)
fila 2 H=3.4 (26.4%)
fila 3 H=2.2 (17.0%)
25% Skin NATURAL
25% Skin HAMMER B.
25% Skin COMB B.
25% Skin MATT



LIGHT CLIFF NERO 4.8X59.8cm

LIGHT CLIFF

4.8x59.8cm



SOPHIA BEIGE



YUNA DARK



NERO

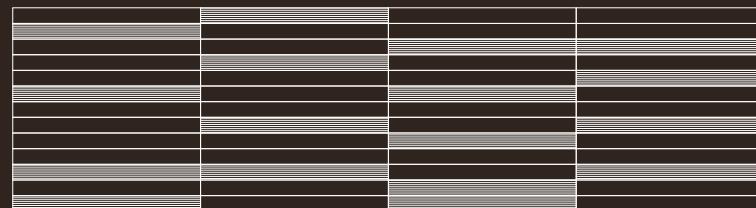

Size 4.8x59.8x1cm

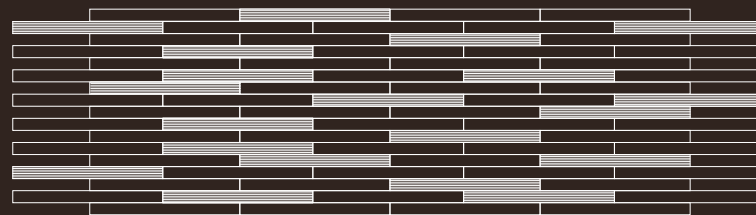

Size 4.8x59.8x1cm



Size 4.8x59.8x1cm

Striking textured solutions wich reflect nature's own power and strength



CLIFF GIALLO PALMAS MODULO B NATURAL



156

CLIFF YUNA DARK MODULO B BRUSH



CLIFF TALA BEIGE MODULO B NATURAL
CLIFF YUNA DARK MODULO B NATURAL



CLIFF GIALLO PALMAS MODULO B NATURAL





CLIFF GIALLO PALMAS MODULO B NATURAL



CLIFF TALA BEIGE MODULO B NATURAL.



CLIFF GIALLO PALMAS MODULO B NATURAL.

CLIFF

TALA BEIGE



YUNA DARK



GIALLO PALMAS

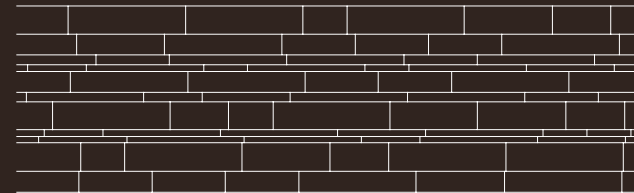

22.7cm
Modulo A
H=22.7cm
1 fila H=9.8 (43.2%)
1 fila H=7.3 (32.1%)
1 fila H=3.4 (15.0%)
1 fila H=2.2 (9.7%)

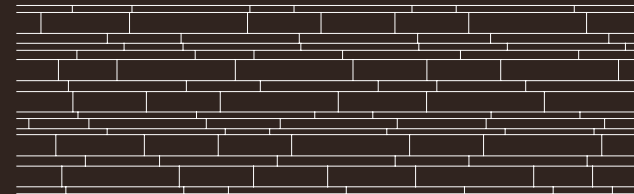

12.9cm
Modulo B
H=12.9cm
1 fila H=7.3 (56.6%)
1 fila H=3.4 (26.4%)
1 fila H=2.2 (17.0%)

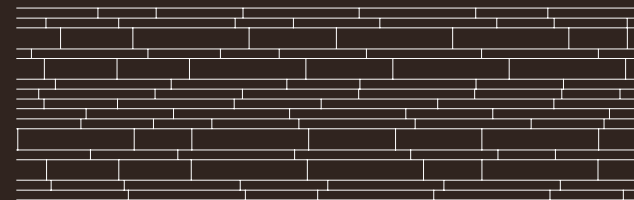

31.6cm
Modulo C
H=31.6cm
2 fila H=7.3 (46.2%)
5 fila H=3.4 (53.8%)

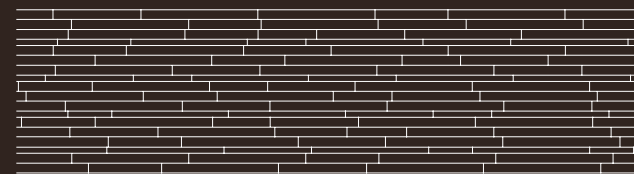

12.4cm
Modulo D
H=12.4cm
3 fila H=3.4 (82.2%)
1 fila H=2.2 (17.8%)



MOSAICOCONTEMPORANEO



| MOSAICO CONTEMPORANEO

Forme geometriche pure per composizioni dal carattere rigoroso e decorativo. Il mosaico, con le sue sfumature e il suo prestigio, torna alla ribalta ricercando e reinterpretando forme geometriche pure, traendo ispirazione dal passato e dal futuro. Altro elemento che entra in gioco è la sfumatura superficiale dettata da lavorazioni e successive spazzolature della superficie scabra che ripropongono al tatto la morbidezza e il calore del cuoio.

Geometrical shapes applied to rigorous and decorative patterns. Mosaic's prestige and natural nuances give a new interpretation of pure geometrical shapes, taking inspiration both from the past and the future. The processings and further brushings of the rough stone make the surface as smooth and warm as leather.

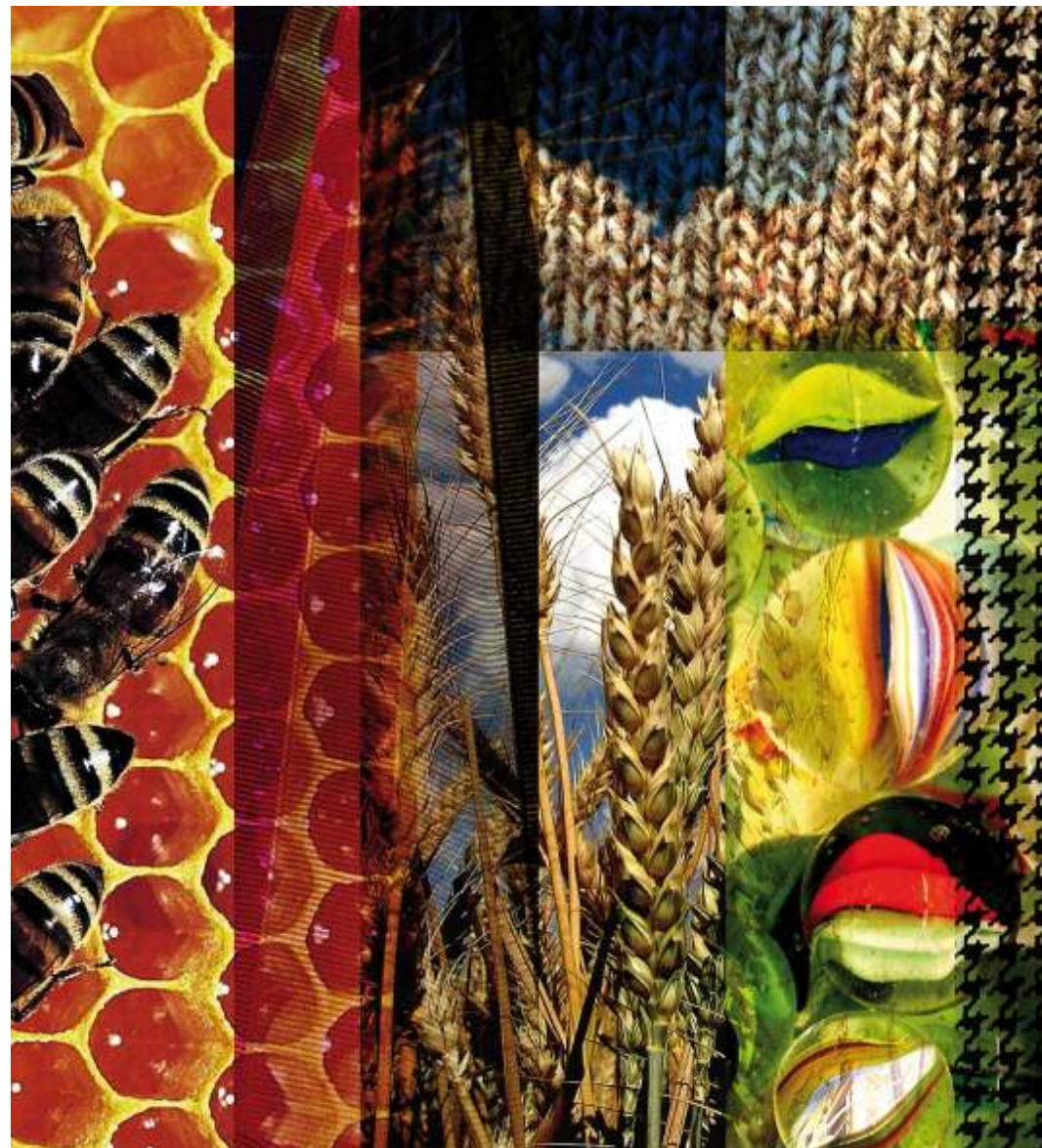

NIDO D'APE BIANCO CARRARA



Fragments of an infinite surface



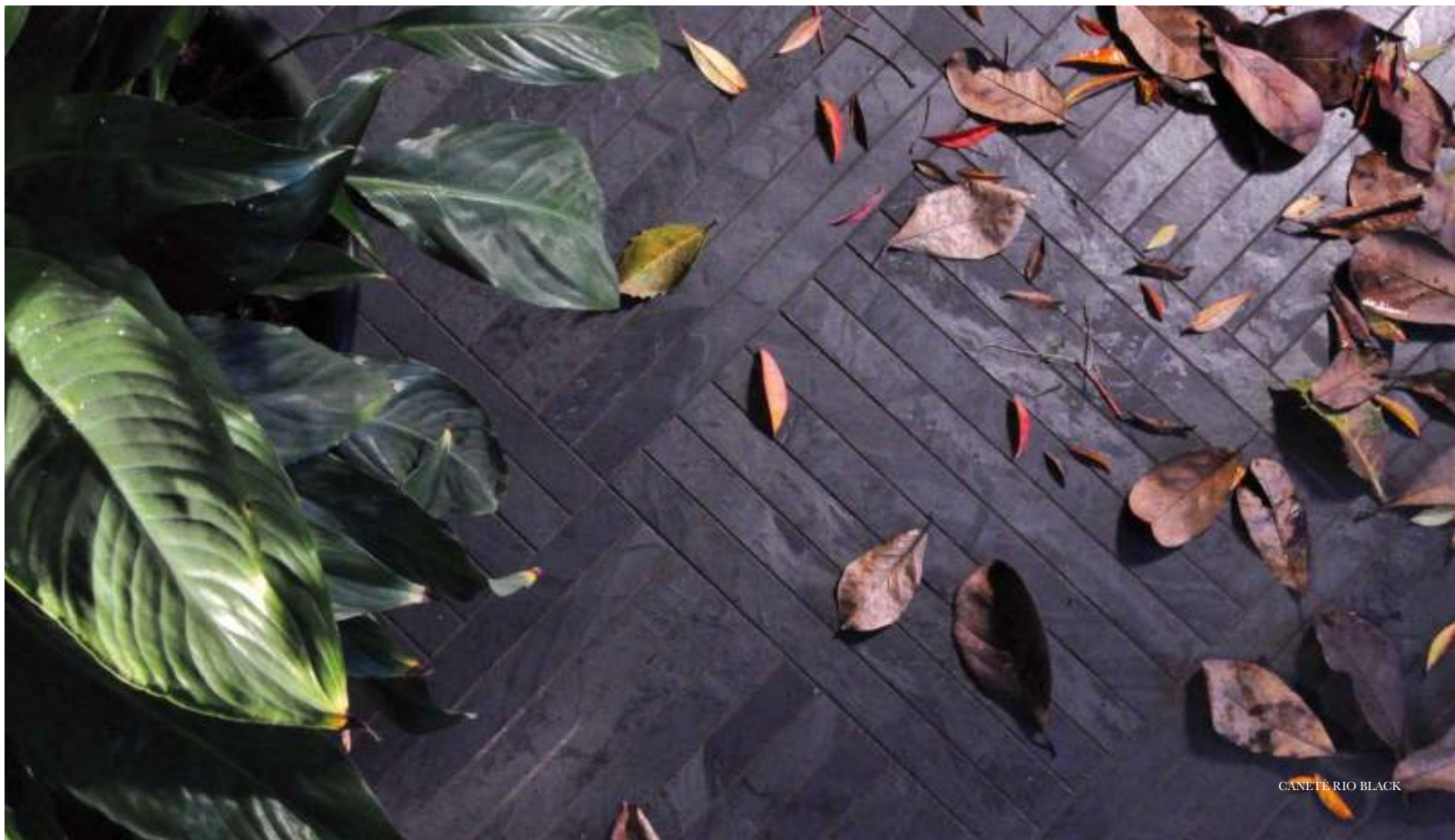

CANET RIO BLACK



CANETÈ NERO MIRROR MATT 20%



MATRIX 5 NERO HAMMER B. 100%



POIS LARGE NERO

*A new interpretation of pure
geometrical shapes,
taking inspiration both from the
past and the future.*



POIS SMALL.ROSSO PERSIA



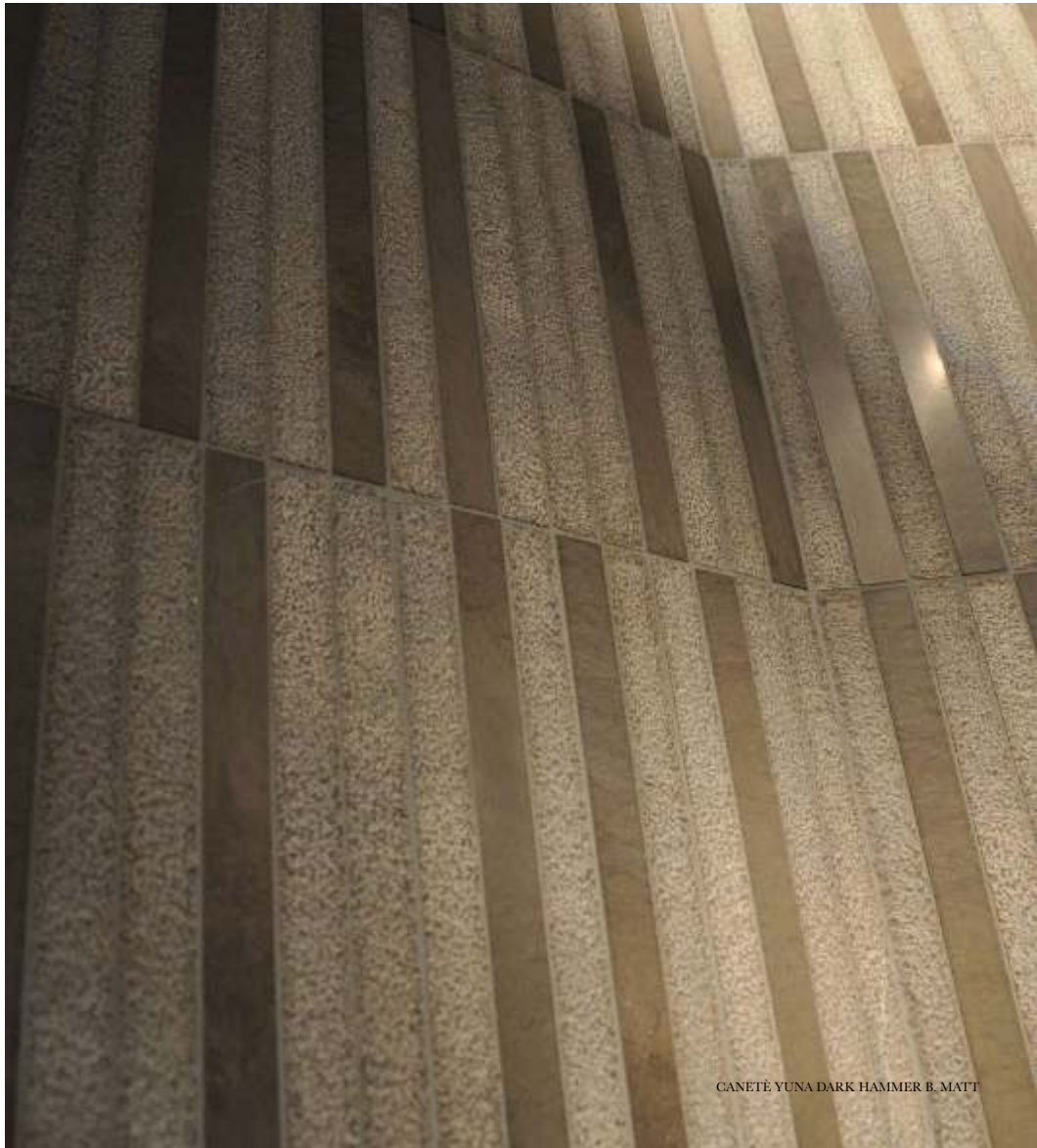

CANETÉ YUNA DARK HAMMER B. MATT

PIED DE POULE NERO | BIANCO CARRARA



TRECCIA BIANCO CARRARA



CANETÈ RIO BLACK



NIDO D'APE ARDESIA NERA NATURAL



MOSAICOCONTEMPORANEO|Matt

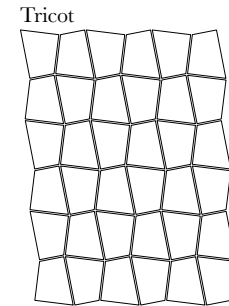
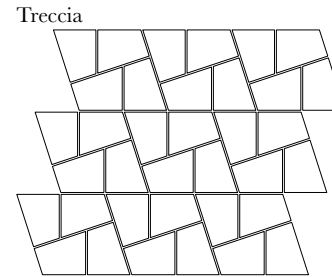
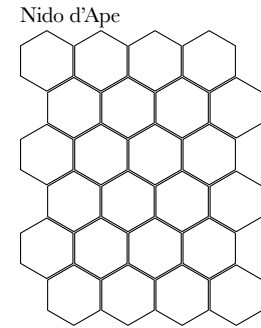
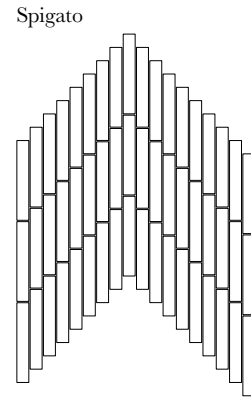
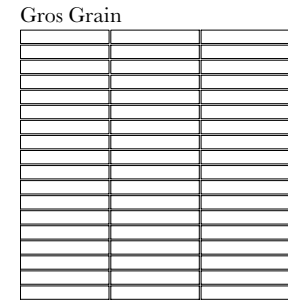
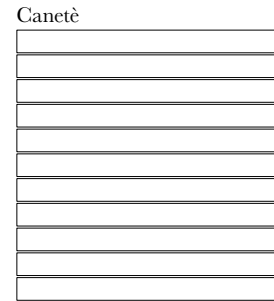
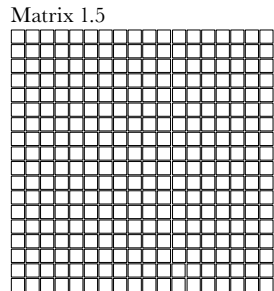
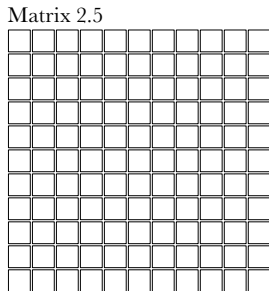
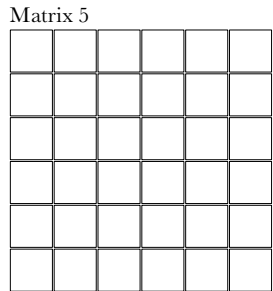
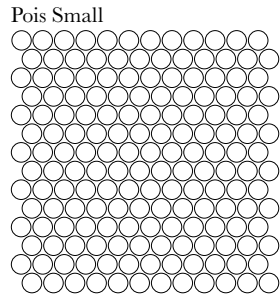
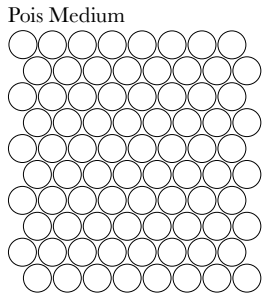
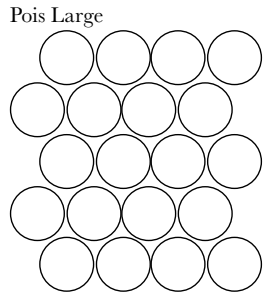



192

NERO



MOSAICO CONTEMPORANEO | Matt

POIS LARGE



Ø 6.7cm

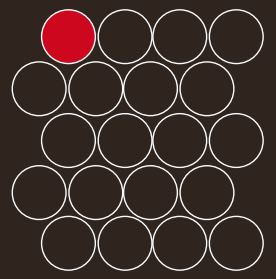

31x31cm

- BOTTICINO
- SOPHIA BEIGE
- CREMASTONE
- GIALLO PALMAS
- TRAVERTINO CHIARO
- TRAVERTINO NOCE
- ROSSO PERSIA
- ARDESIA NERA
- ARDESIA VERDE
- ARDESIA BORDEAUX
- CORTEN
- YUNA DARK
- KAISER BROWN
- ROOTS
- BIANCO CARRARA
- BIANCONE
- GRIGIO BARDIGLIO
- NERO
- RIO BLACK



194

SOPHIA BEIGE



MOSAICO CONTEMPORANEO | Matt

POIS MEDIUM



Ø 3.3cm

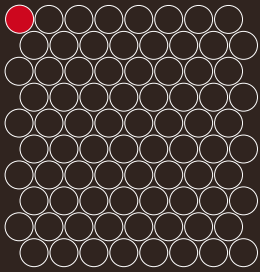

29.5x30.5cm

- BOTTICINO
- SOPHIA BEIGE
- CREMASTONE
- GIALLO PALMAS
- TRAVERTINO CHIARO
- TRAVERTINO NOCE
- ROSSO PERSIA
- ARDESIA NERA
- ARDESIA VERDE
- ARDESIA BORDEAUX
- CORTEN
- YUNA DARK
- KAISER BROWN
- ROOTS
- BIANCO CARRARA
- BIANCONE
- GRIGIO BARDIGLIO
- NERO
- RIO BLACK



ROSSO PERSIA



MOSAICO CONTEMPORANEO | Matt

POIS SMALL



Ø 2.3cm

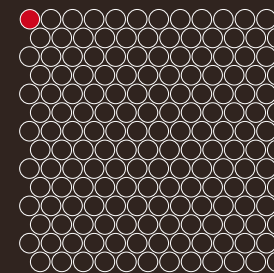

31.5x31cm





MOSAICO CONTEMPORANEO | Matt

MATRIX 5

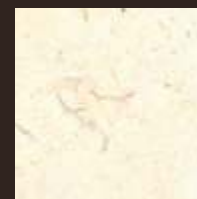

4.8X4.8cm

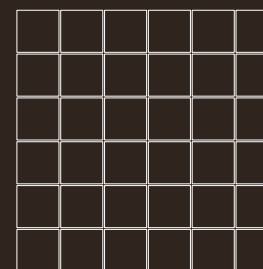

29.8x29.8cm

	BOTTICINO
	SOPHIA BEIGE
	CREMA STONE
	GIALLO PALMAS
	TRAVERTINO CHIARO
	TRAVERTINO NOCE
	ROSSO PERSIA
	ARDESIA NERA
	ARDESIA VERDE
	ARDESIA BORDEAUX
	CORTEN
	YUNA DARK
	KAISER BROWN
	ROOTS
	BIANCO CARRARA
	BIANCONE
	GRIGIO BARDIGLIO
	NERO
	RIO BLACK

GIALLO PALMAS



MOSAICO CONTEMPORANEO | Matt

MATRIX 2.5



2.5x2.5cm

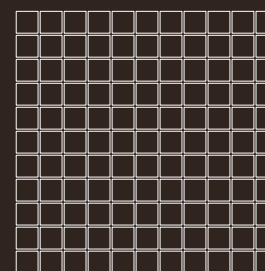

29.8x29.8cm





MOSAICO CONTEMPORANEO | Matt

MATRIX 1.5



1.5x1.5cm

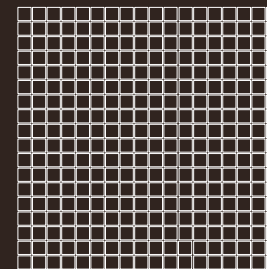

30x30cm





MOSAICO CONTEMPORANEO | Matt

CANETÈ

29.8x2.5cm

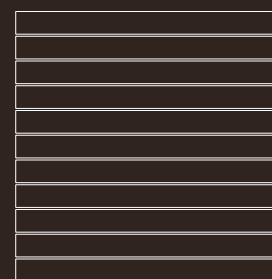

29.8x29.8cm

- BOTTICINO
- SOPHIA BEIGE
- CREMASTONE
- GIALLO PALMAS
- TRAVERTINO CHIARO
- TRAVERTINO NOCE
- ROSSO PERSIA
- ARDESIA NERA
- ARDESIA VERDE
- ARDESIA BORDEAUX
- CORTEN
- YUNA DARK
- KAISER BROWN
- ROOTS
- BIANCO CARRARA
- BIANCONE
- GRIGIO BARDIGLIO
- NERO
- RIO BLACK

CREMASTONE

204



MOSAICO CONTEMPORANEO | Matt

GROS GRAIN

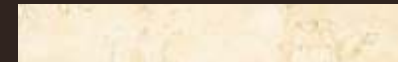

9.8x1.5cm

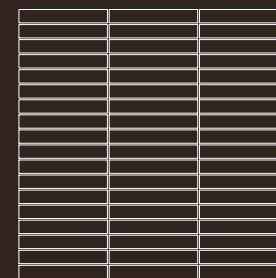

29.8x29.8cm

-  BOTTICINO
-  SOPHIA BEIGE
-  CREMA STONE
-  GIALLO PALMAS
-  TRAVERTINO CHIARO
-  TRAVERTINO NOCE
-  ROSSO PERSIA
-  ARDESIA NERA
-  ARDESIA VERDE
-  ARDESIA BORDEAUX
-  CORTEN
-  YUNA DARK
-  KAISER BROWN
-  ROOTS
-  BIANCO CARRARA
-  BIANCONE
-  GRIGIO BARDIGLIO
-  NERO
-  RIO BLACK

206

ROOTS



MOSAICO CONTEMPORANEO | Matt

SPIGATO



9.8x1.5cm

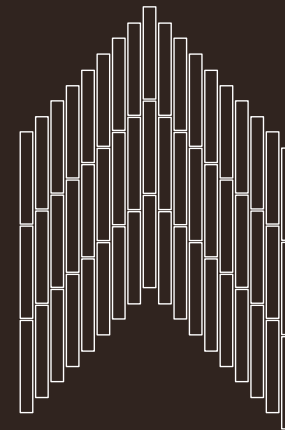

29.5x44.5cm

- BOTTICINO
- SOPHIA BEIGE
- CREMASTONE
- GIALLO PALMAS
- TRAVERTINO CHIARO
- TRAVERTINO NOCE
- ROSSO PERSIA
- ARDESIA NERA
- ARDESIA VERDE
- ARDESIA BORDEAUX
- CORTEN
- YUNA DARK
- KAISER BROWN
- ROOTS
- BIANCO CARRARA
- BIANCONE
- GRIGIO BARDIGLIO
- NERO
- RIO BLACK



210

YUNA DARK



MOSAICO CONTEMPORANEO | Matt

NIDO D'APE



13.5cm

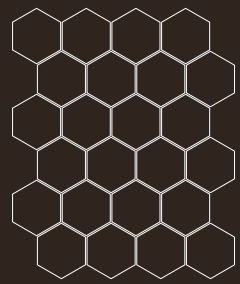

31.5x38.5cm

- BOTTICINO
- SOPHIA BEIGE
- CREMASTONE
- GIALLO PALMAS
- TRAVERTINO CHIARO
- TRAVERTINO NOCE
- ROSSO PERSIA
- ARDESIA NERA
- ARDESIA VERDE
- ARDESIA BORDEAUX
- CORTEN
- YUNA DARK
- KAISER BROWN
- ROOTS
- BIANCO CARRARA
- BIANCONE
- GRIGIO BARDIGLIO
- NERO
- RIO BLACK

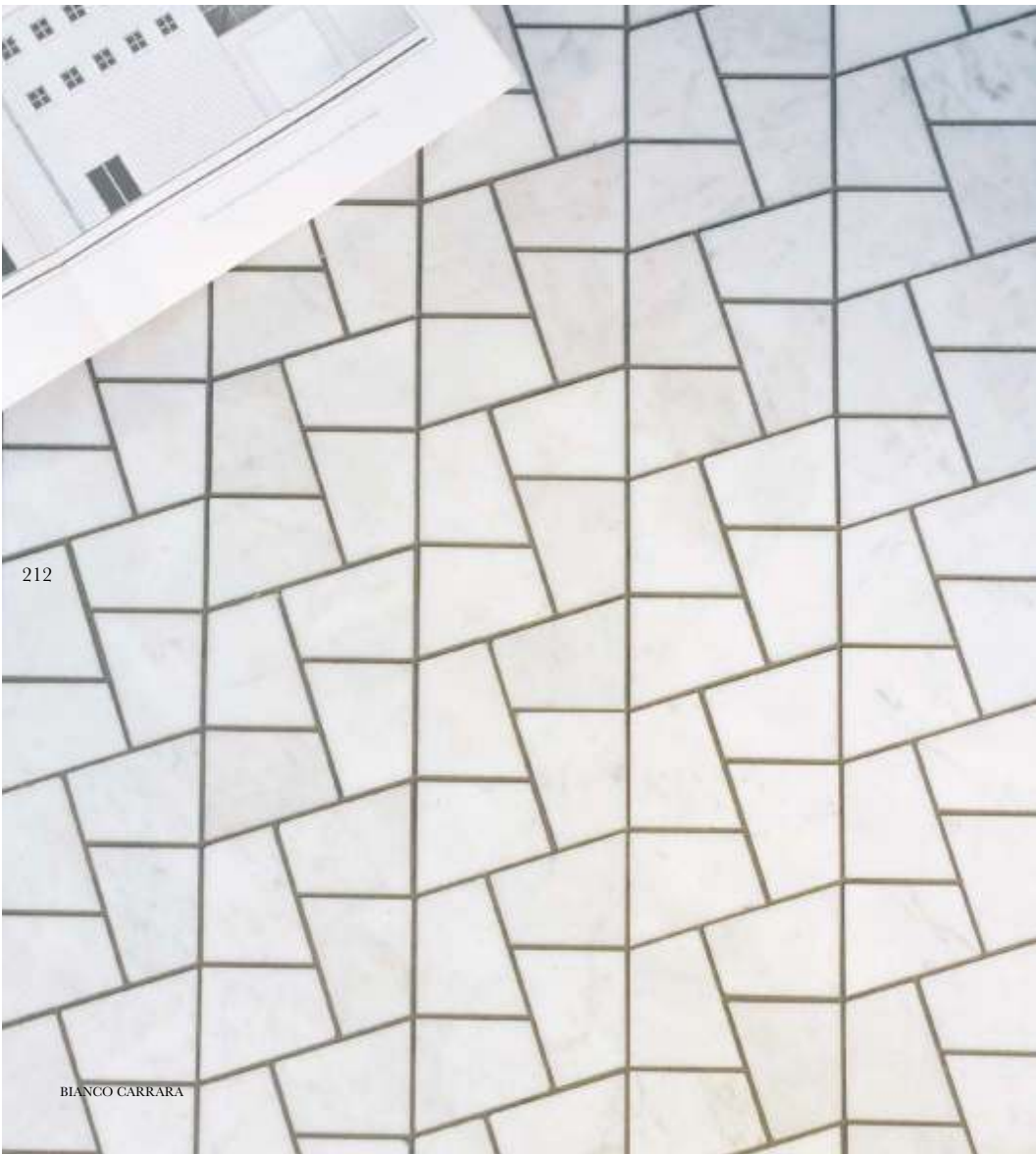

MOSAICO CONTEMPORANEO | Matt

TRECCIA



6x5cm

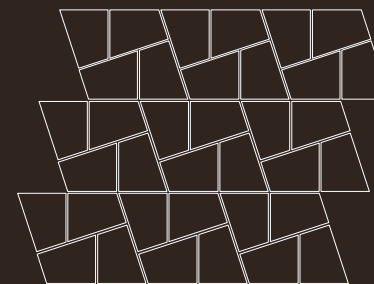

39x28.5cm





MOSAICO CONTEMPORANEO | Matt

TRICOT



6x5cm

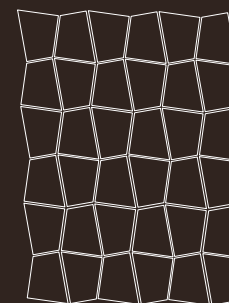

28x35.5cm





MOSAICOCONTEMPORANEO | B&W

Pois Medium 20%

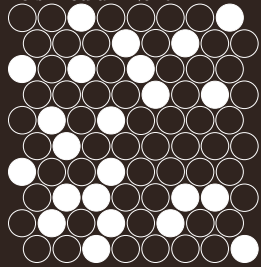

Treccia

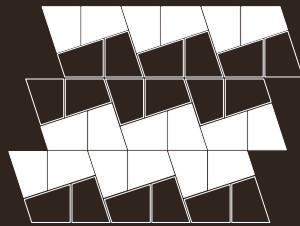

Matrix 5

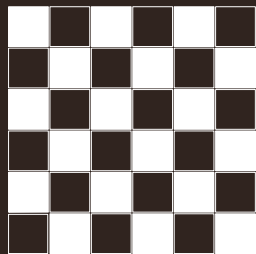

Gros Grain

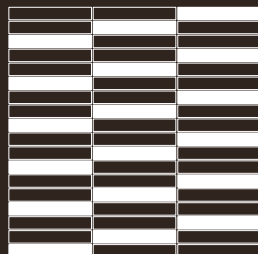

Spigato A

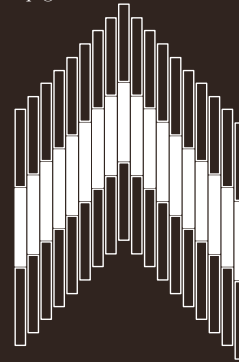

Spigato B

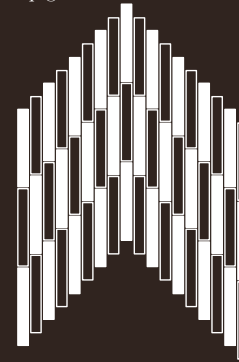

Tricot A

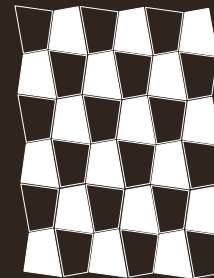

Nido d'Ape A

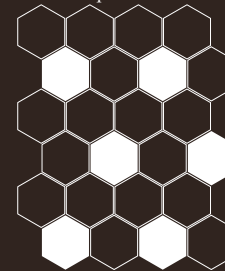

Pied de poule A

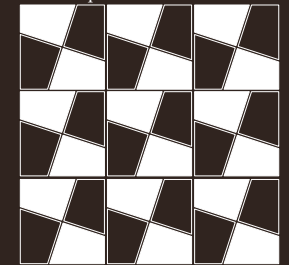

Tricot B

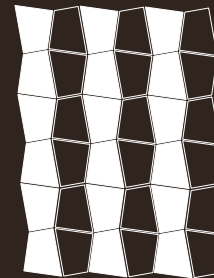

Nido d'Ape B

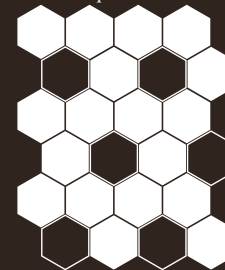

Pied de poule B

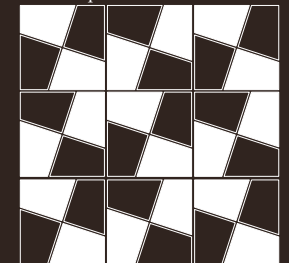



MOSAICOCONTEMPORANEO | Skins

Pois Large

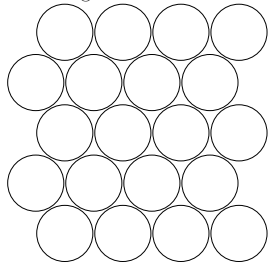

Matrix 5

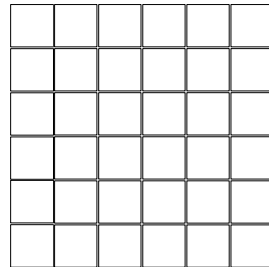

Canetè

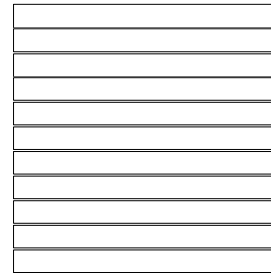

Gors Grain

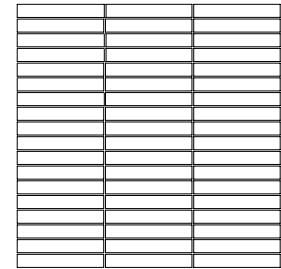

Nido d'Ape

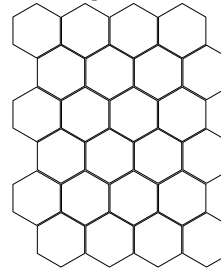

Pied de poule

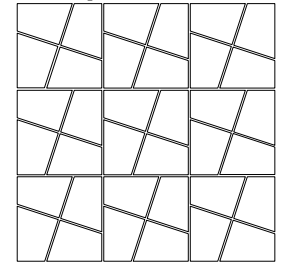

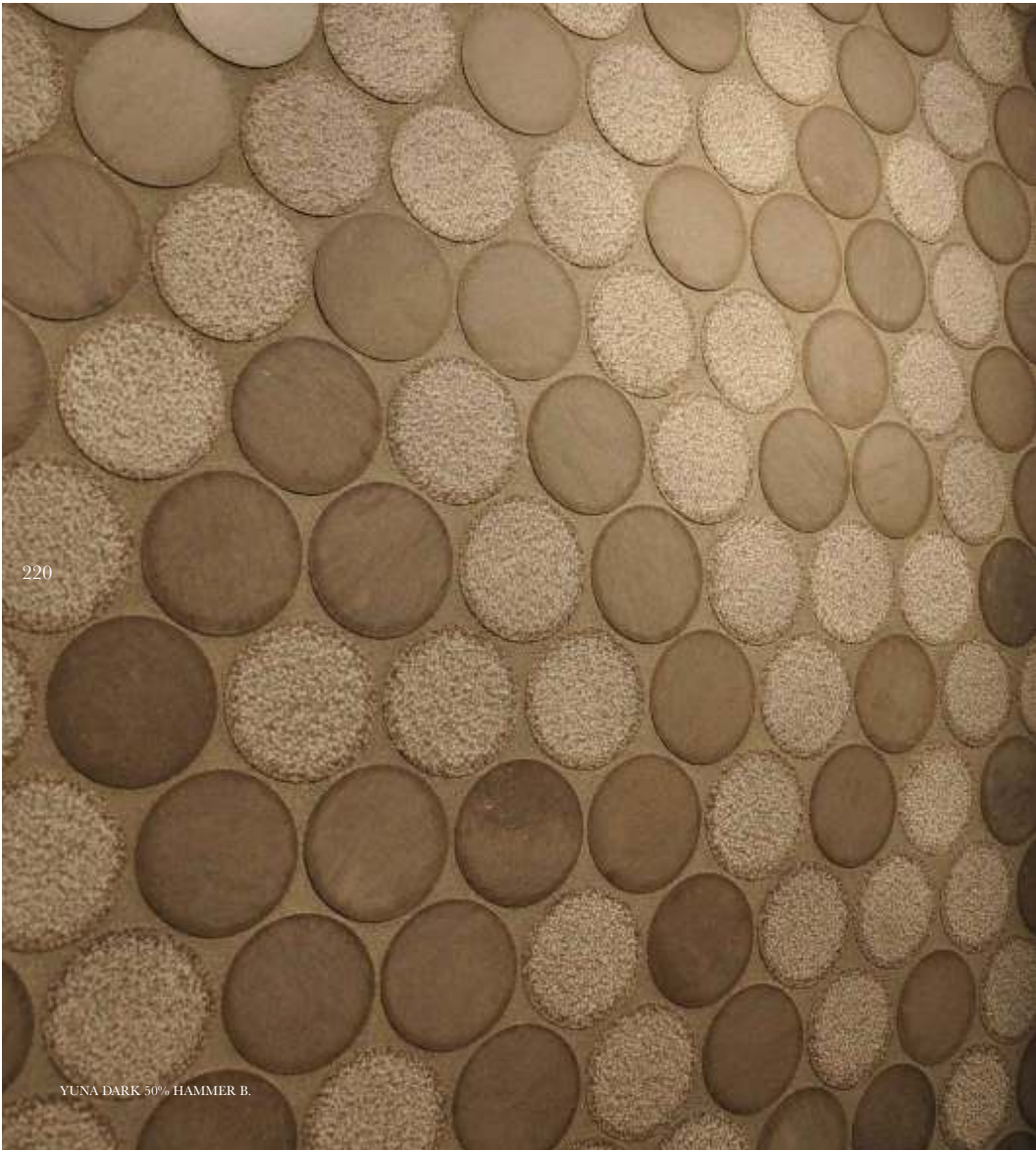

220

YUNA DARK 50% HAMMER B.

MOSAICOCONTEMPORANEO | Skins



POIS LARGE
HAMMER B.

20%

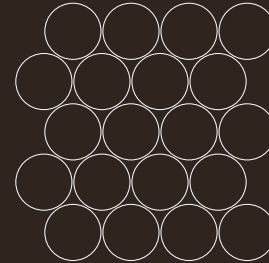

50%

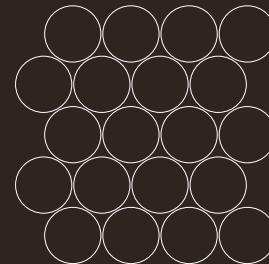

100%

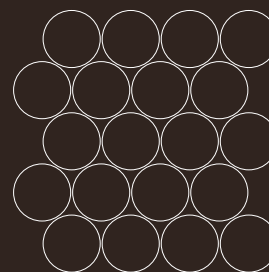

BIANCO CARRARA



SOPHIA BEIGE



KAISER BROWN



YUNA DARK



NERO

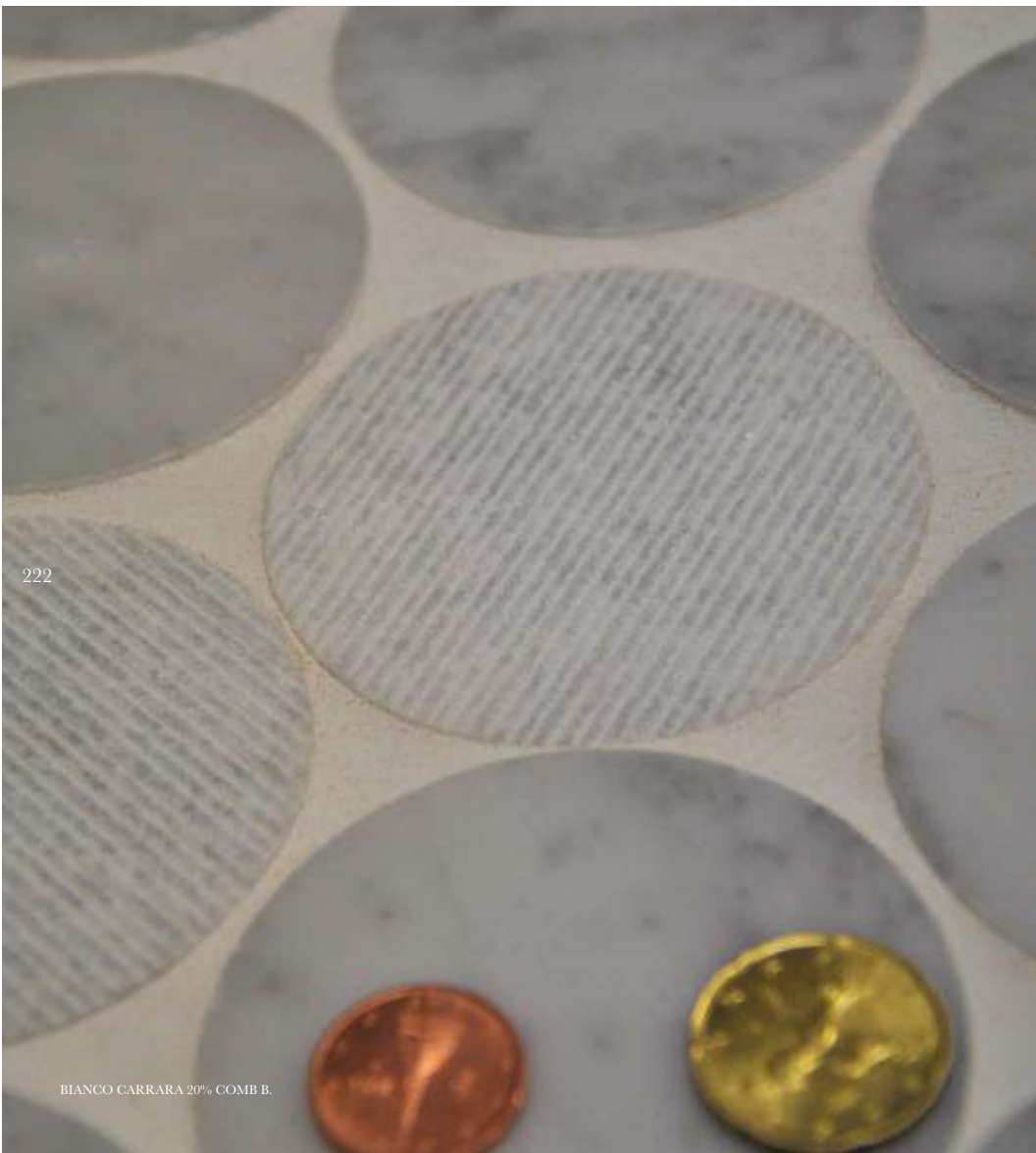

222

BIANCO CARRARA 20% COMB B.

MOSAICOCONTEMPORANEO | Skins



POIS LARGE
COMB B.

20%

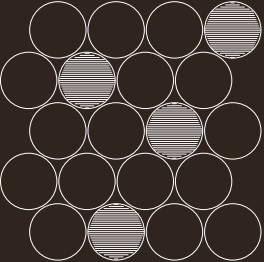

50%

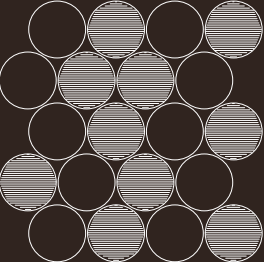

100%

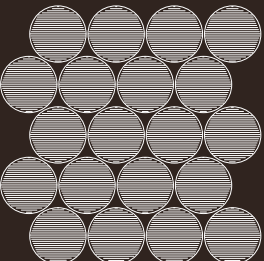

BIANCO CARRARA



SOPHIA BEIGE



KAISER BROWN



YUNA DARK



NERO



224

NERO 100% HAMMER B.

MOSAICOCONTEMPORANEO | Skins



MATRIX 5
HAMMER B.

20%

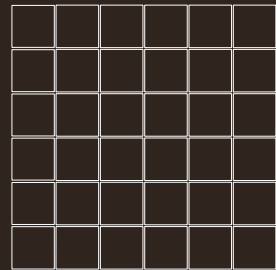

50%

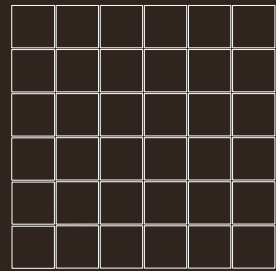

100%

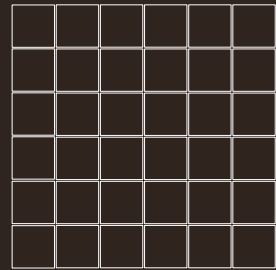

BIANCO CARRARA



SOPHIA BEIGE



KAISER BROWN



YUNA DARK

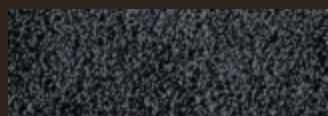

NERO



MOSAICOCONTEMPORANEO | Skins



MATRIX 5
COMB B.

20%

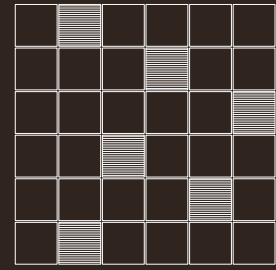

50%

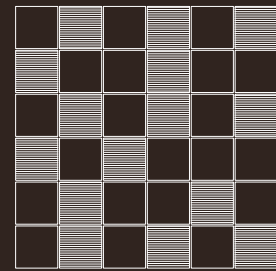

100%

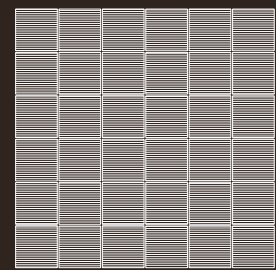

BIANCO CARRARA



SOPHIA BEIGE



KAISER BROWN

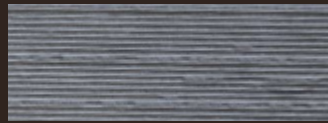

YUNA DARK

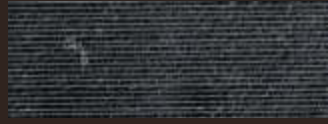

NERO



228

NERO 50% HAMMER B.

MOSAICOCONTEMPORANEO | Skins



CANETÈ
HAMMER B.

20%



50%



100%



BIANCO CARRARA



SOPHIA BEIGE



KAISER BROWN



YUNA DARK

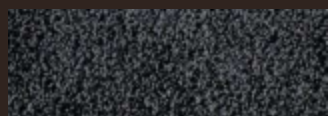

NERO



230

SOPHIA BEIGE 100% COMB B.

MOSAICOCONTEMPORANEO | Skins



CANETÈ
COMB B.

20%

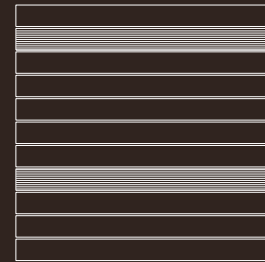

50%

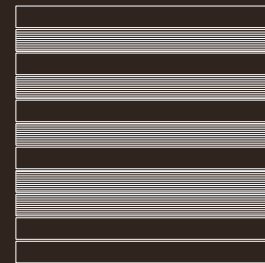

100%

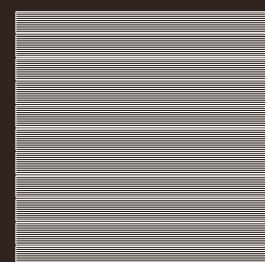

BLANCO CARRARA



SOPHIA BEIGE



KAISER BROWN



YUNA DARK



NERO



MOSAICOCONTEMPORANEO|Skins



GROS GRAIN HAMMER B.

20%

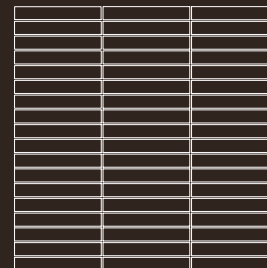

BIANCO CARRARA

50%

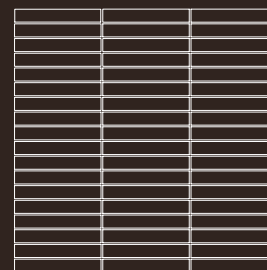

SOPHIA BEIGE

100%

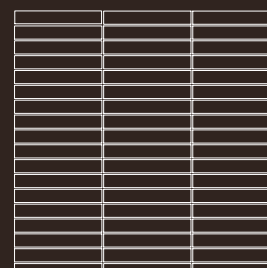

KAISER BROWN



YUNA DARK



NERO

BIANCO CARRARA 50% COMB B.



234

NERO 50% COMB B.

MOSAICOCONTEMPORANEO | Skins



GROS GRAIN
COMB B.

20%

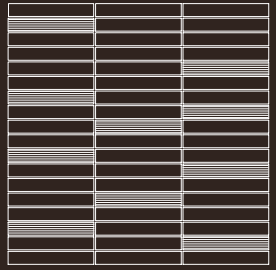

50%

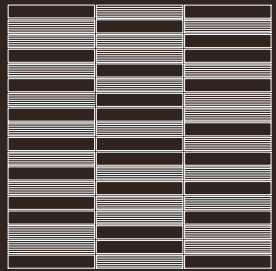

100%

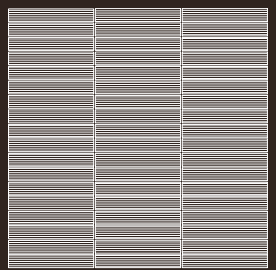

BIANCO CARRARA



SOPHIA BEIGE



KAISER BROWN



YUNA DARK

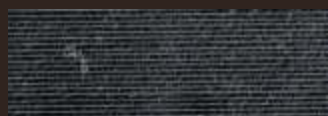

NERO



MOSAICOCONTEMPORANEO | Skins



NIDO D'APE
HAMMER B.

20%

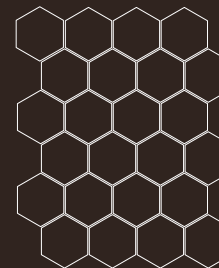

50%

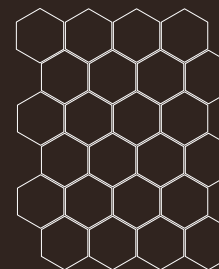

100%

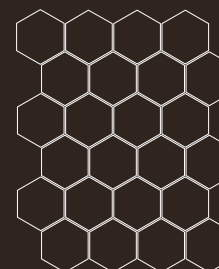

BIANCO CARRARA



SOPHIA BEIGE



KAISER BROWN



YUNA DARK



NERO

KAISER BROWN 100% HAMMER B.



238

CREMASTONE 20% COMB B.

MOSAICOCONTEMPORANEO | Skins



NIDO D'APE
COMB B.

20%

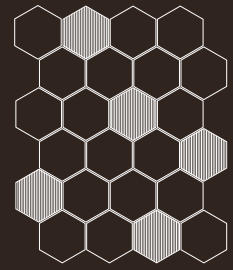

50%

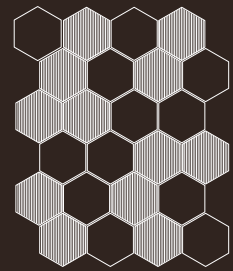

100%

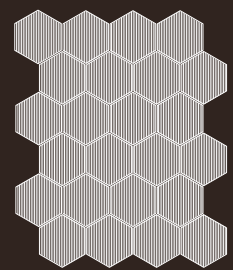

BIANCO CARRARA

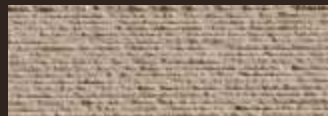

SOPHIA BEIGE



KAISER BROWN



YUNA DARK



NERO



MOSAICOCONTEMPORANEO | Skins



PIED DE POULE
HAMMER B.

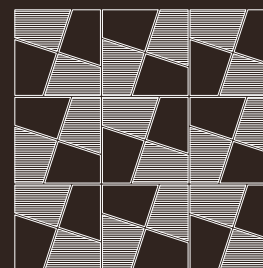
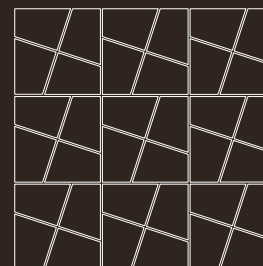

BLANCO CARRARA

SOPHIA BEIGE

KAISER BROWN

YUNA DARK

NERO

COMB B.

BLANCO CARRARA

SOPHIA BEIGE

KAISER BROWN

YUNA DARK

NERO



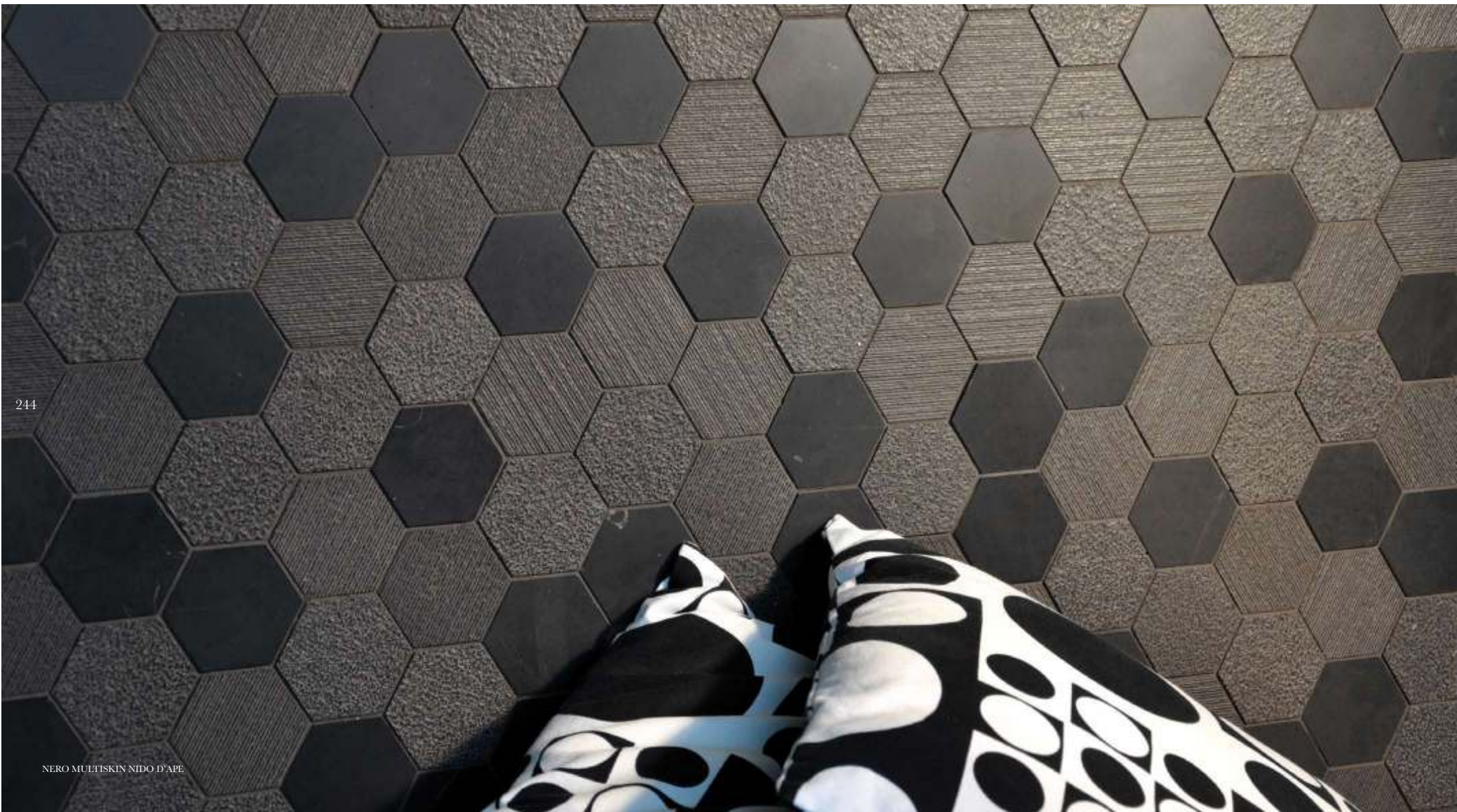

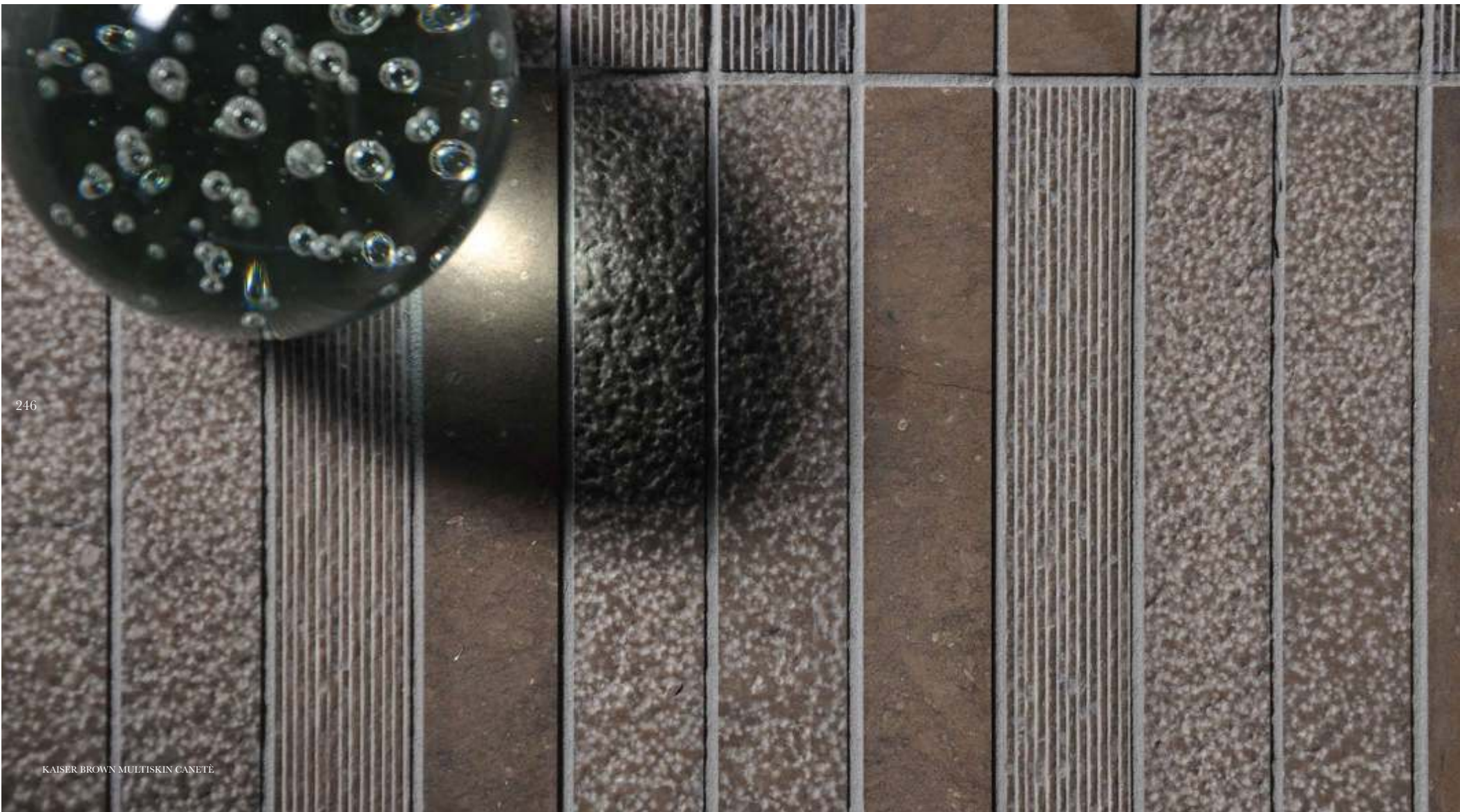

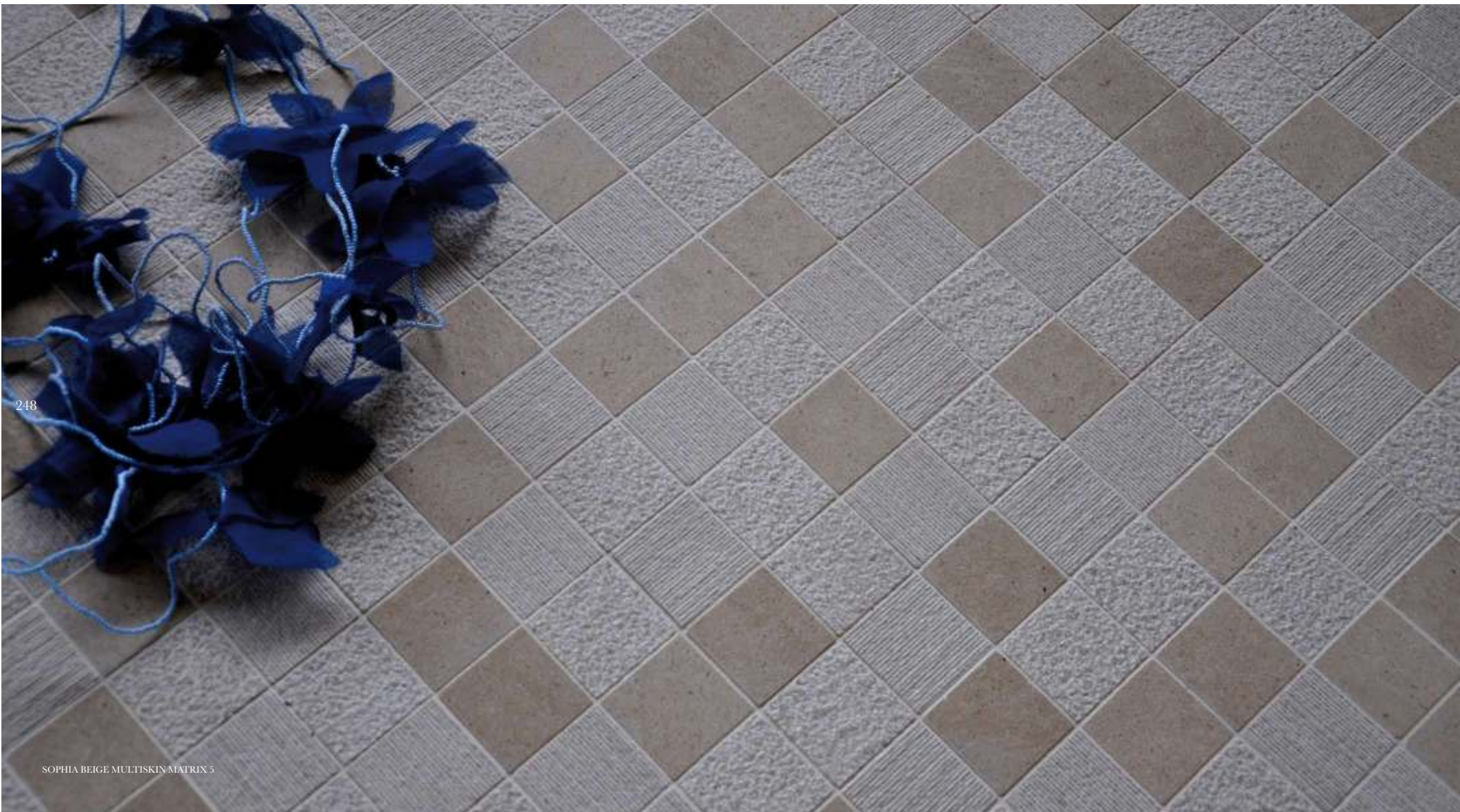



ORION



ORION |

Orion racconta l'emozione di una notte stellata, percepita attraverso una superficie ricercata e luminosa, che brilla e si modula a seconda dell'incedere della luce, indagando nella nostra memoria sensazioni dense e primitive, retaggio di un tempo in cui ancora l'occhio dell'uomo guardava con stupore le stelle nel cielo. Superfici vive, palpitanti di riverberi preziosi che enfatizzano la sobrietà della pietra riletta in un contesto glamour, attuale ed elegante.

Orion transmits the emotion of a starry night, perceived through a refined and bright surface, which shines and gets modelled according to light strength, discovering deep and primitive perceptions in our memory, of a remote time when men could still look at a starry sky in astonishment. Dynamic surfaces suggesting ancient sensations, which enhance stone simplicity seen in a new charming and elegant context.



Fashion, glamour and a starry night

254

ORION SILVER S.220



255

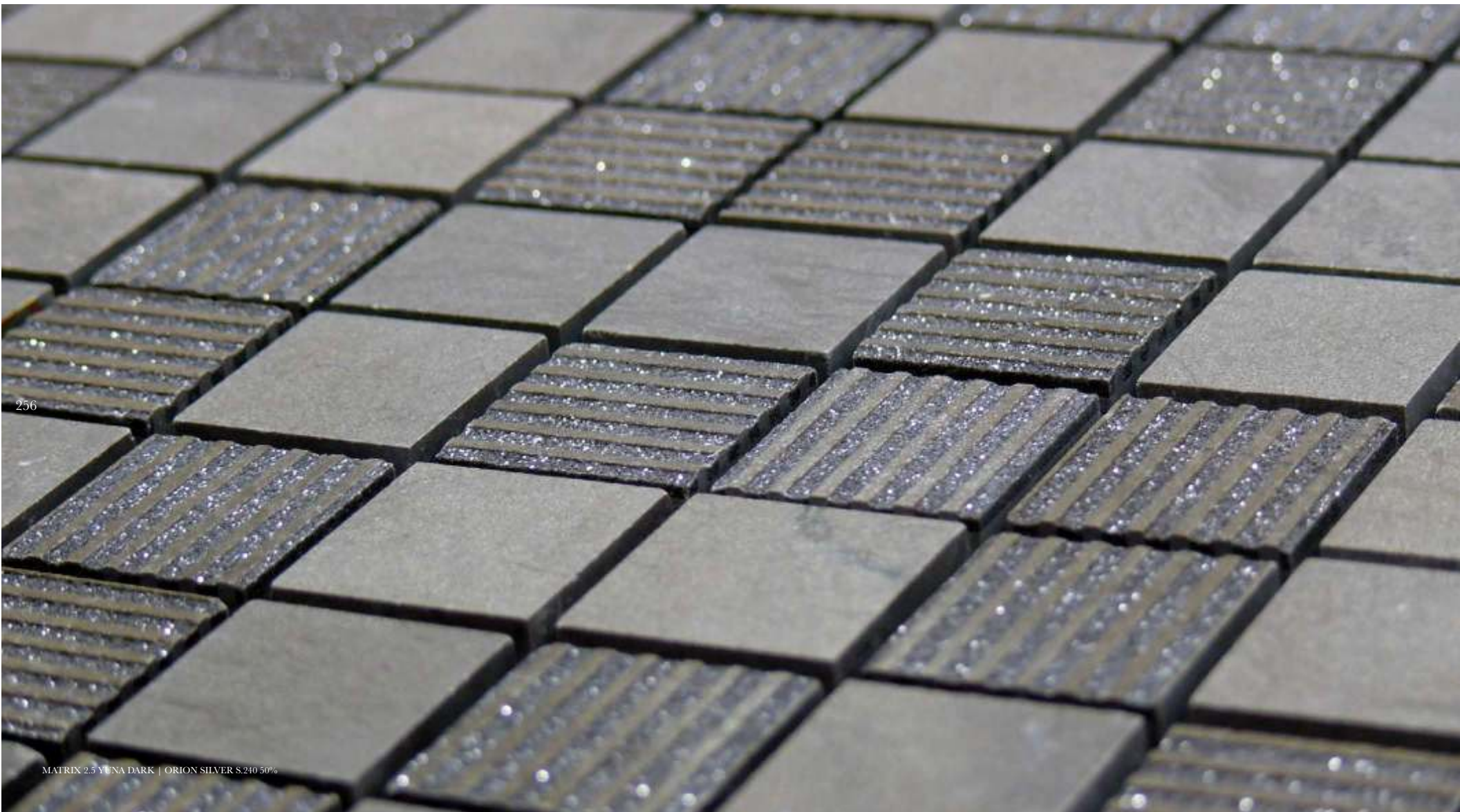

256

MATRIX 2.5 YUNA DARK | ORION SILVER S.240 50%



ORION SILVER S.240





ORION SILVER S.240





ORION SILVER S.280

Refined and bright surface

264



SPIGATO ICE

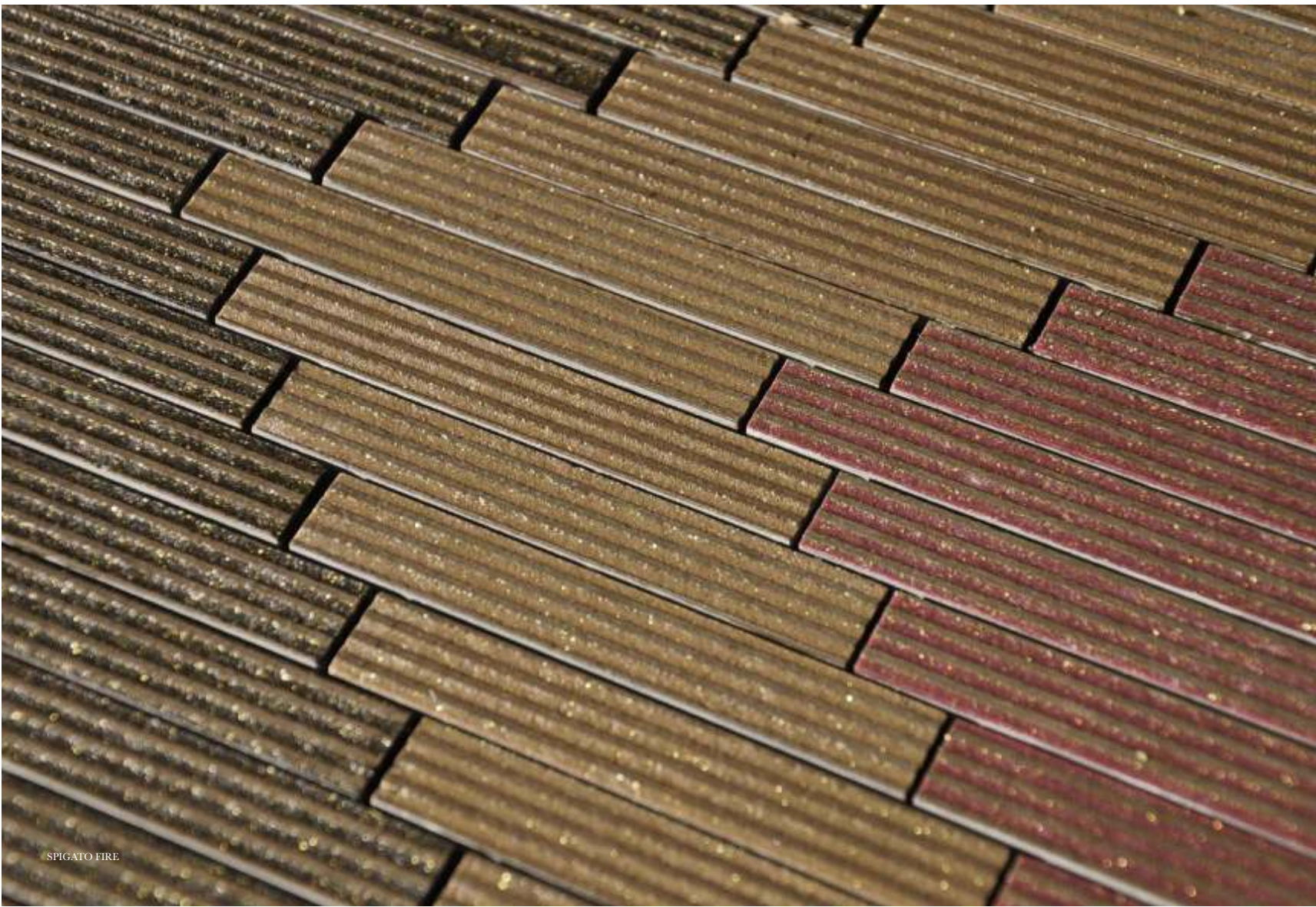

SPIGATO FIRE



ORION GOLD G.280





270

TRICOT ORION SILVER S.280 100%

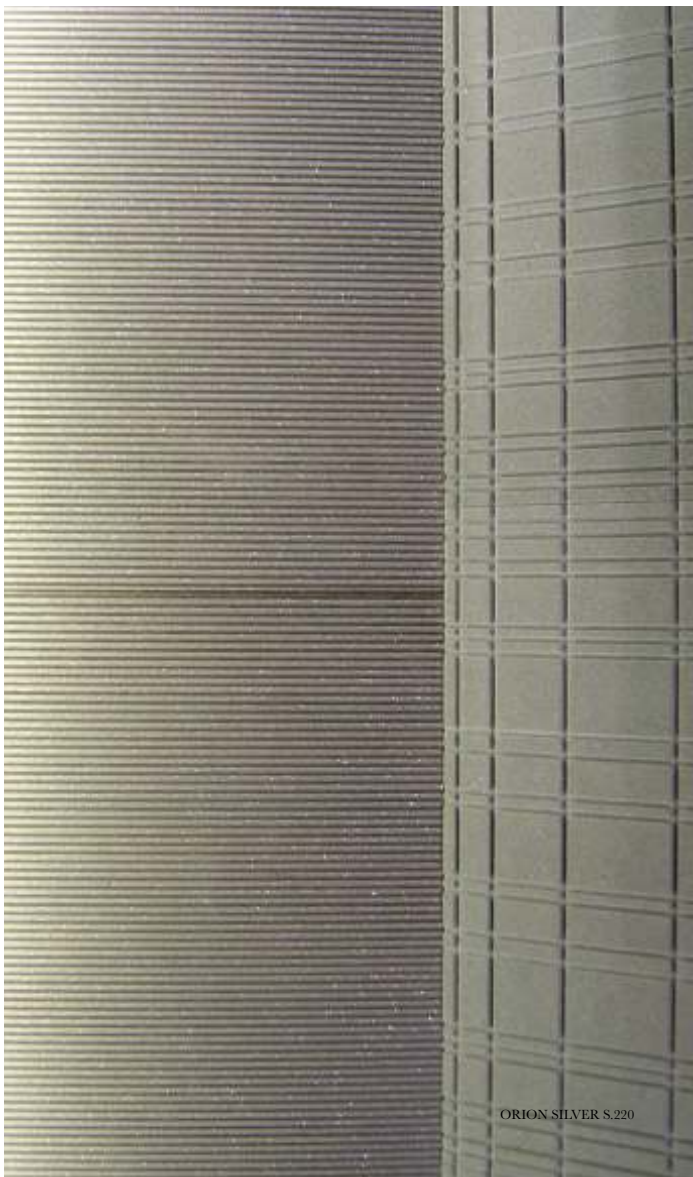

ORION SILVER S.220

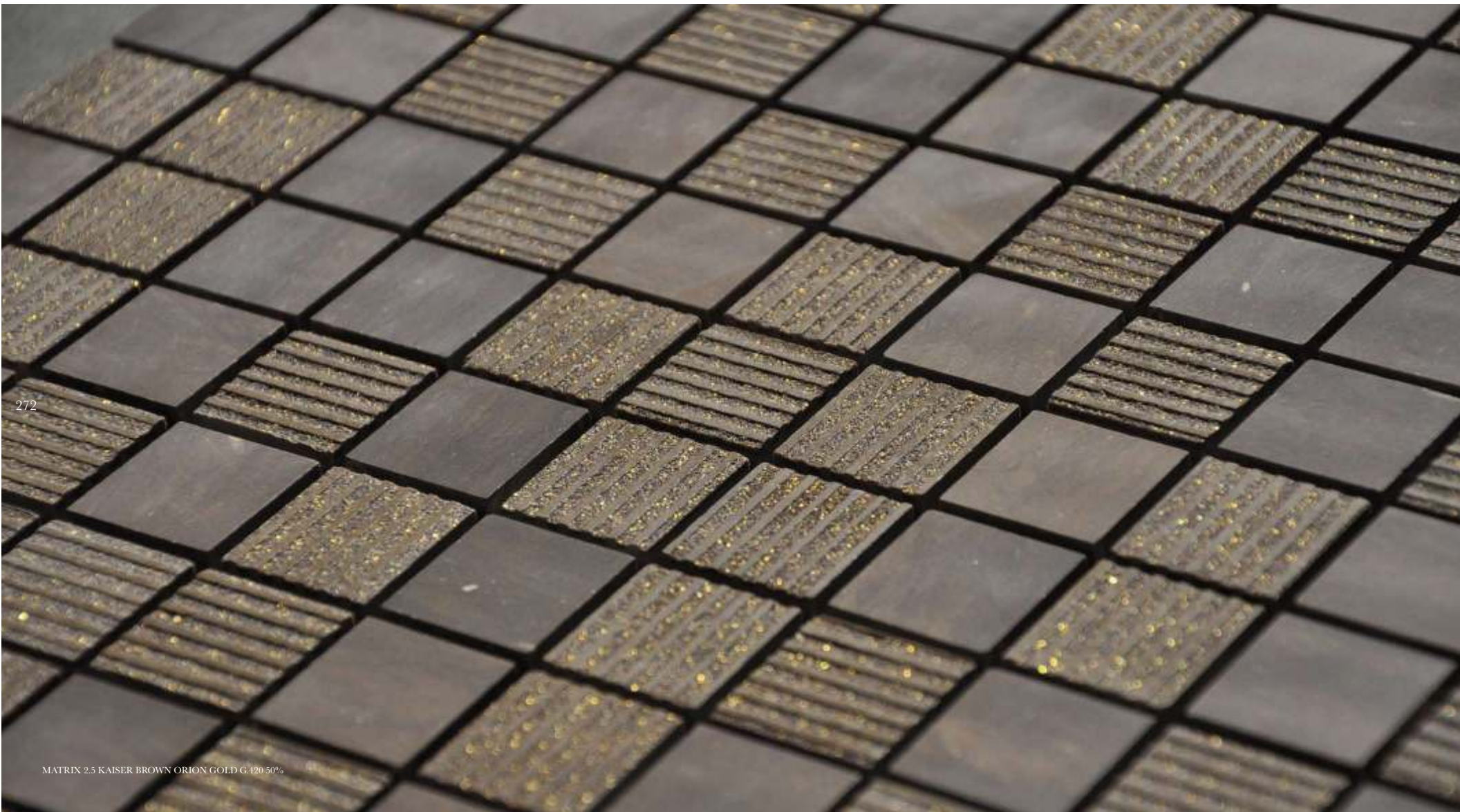

272

MATRIX 2.5 KAISER BROWN ORION GOLD G.420 50%



ORION SILVER



S.220



276

S.280

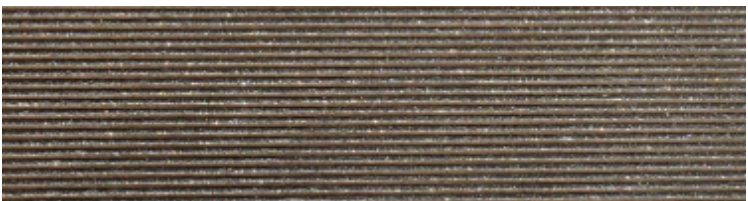

S.240



S.300



ORION GOLD



G.300



277

G.420

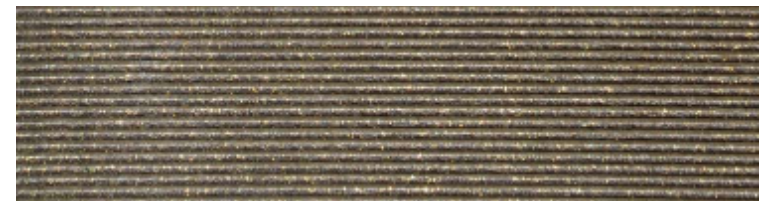

G.240

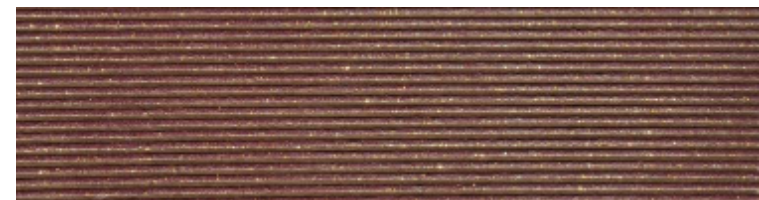

G.360

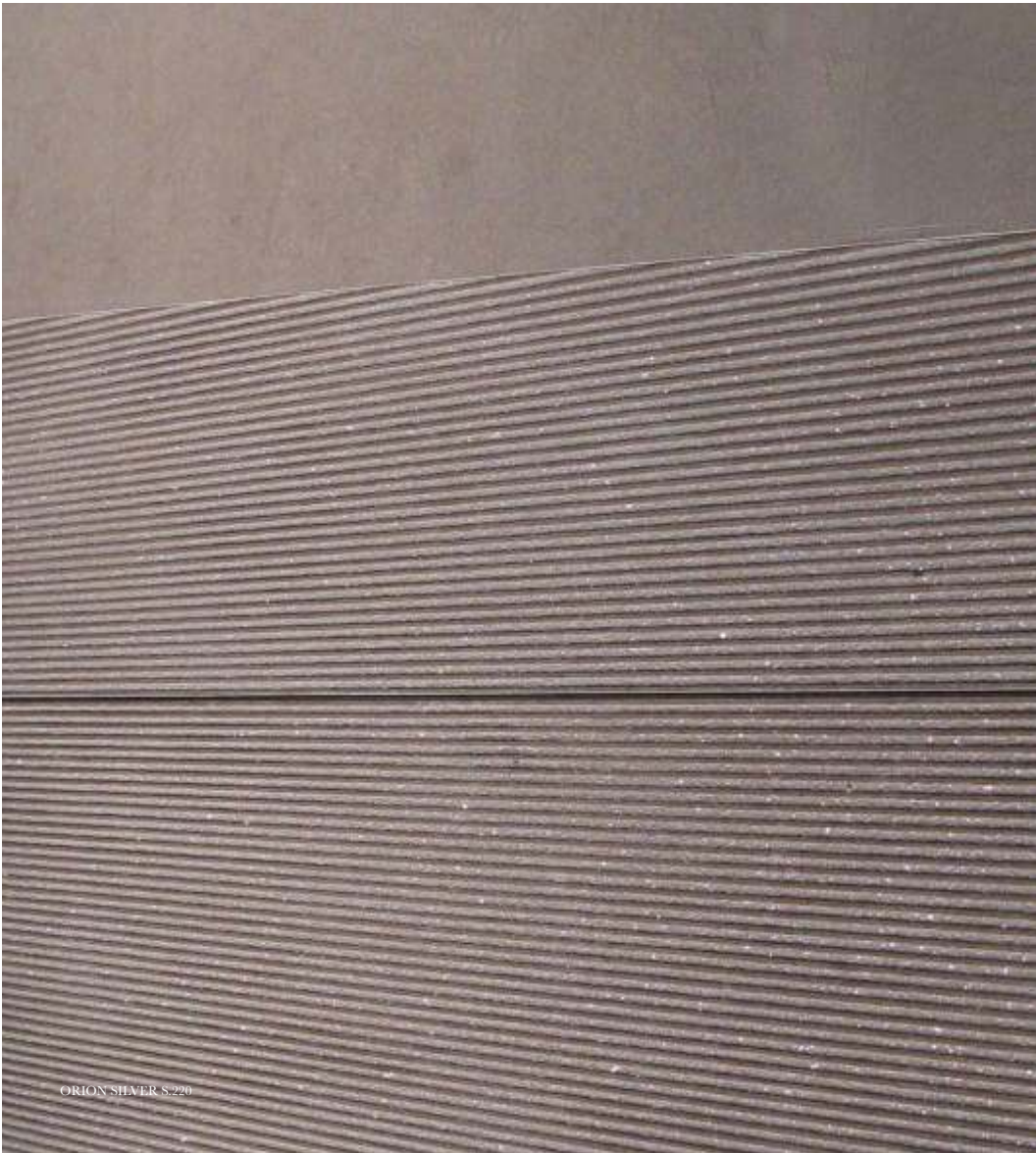

ORION SHAVER S.220



ORION

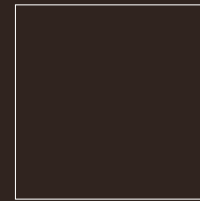

29.8x29.8x1cm

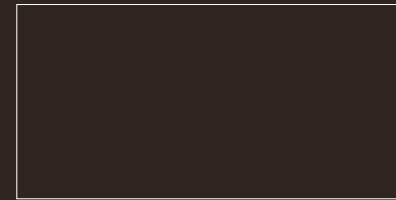

29.8x59.8x1cm

ORION SILVER



S.220



S.280



S.240



S.300

279

ORION GOLD



G.300



G.420



G.240



G.360

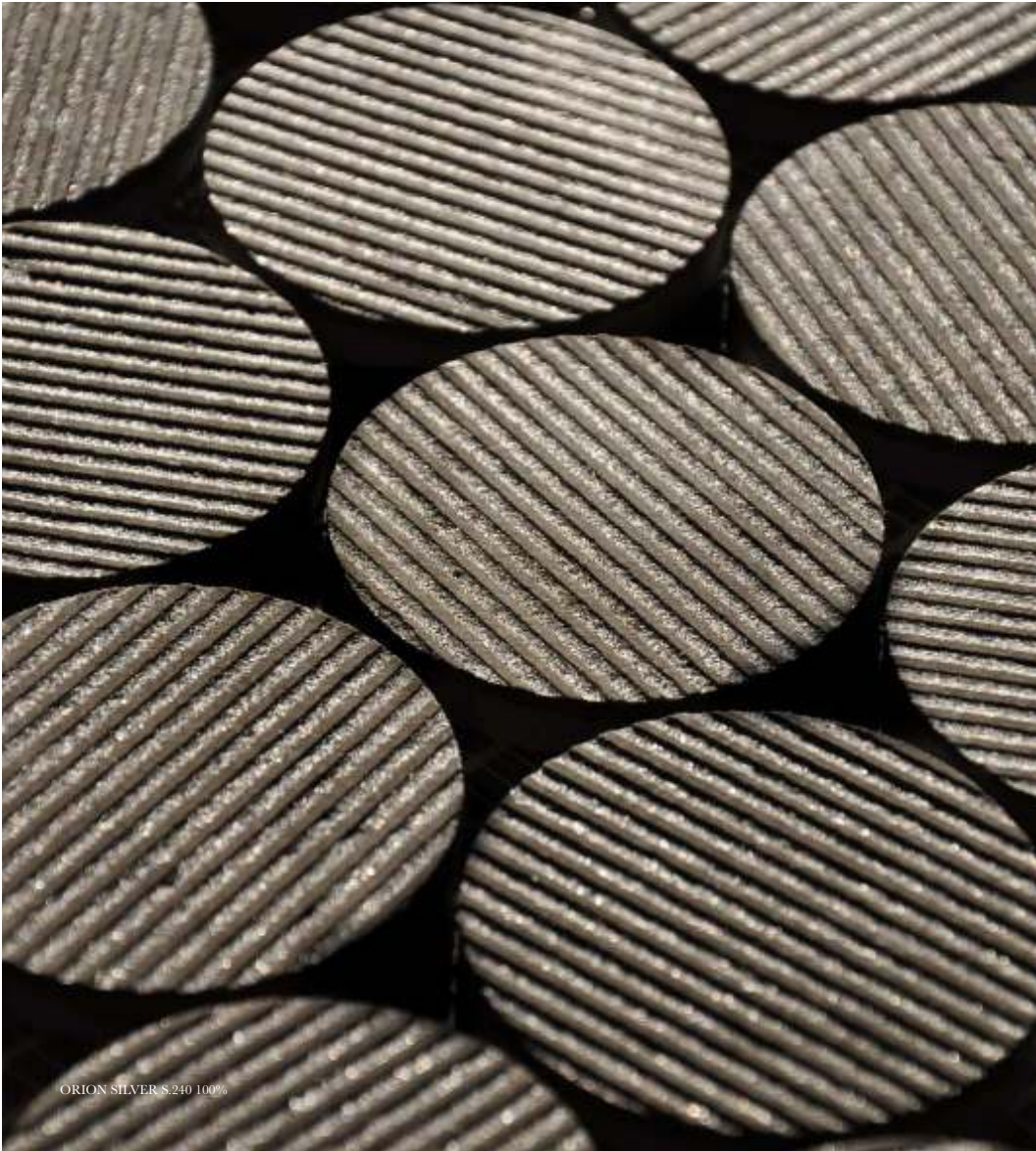

ORION SILVER S.240 100%

ORION POIS LARGE

20%

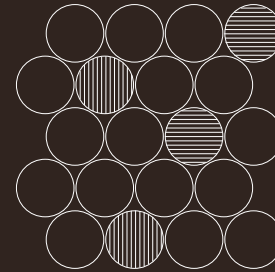

50%

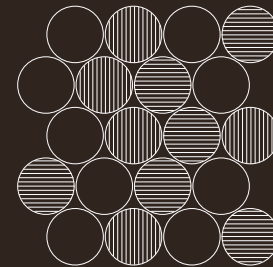

100%

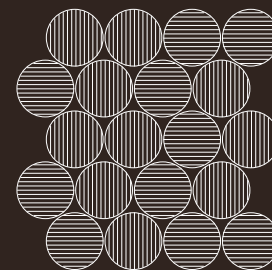



YUNA DARK ORION SILVER S.280 50%

ORION MATRIX 5

20%

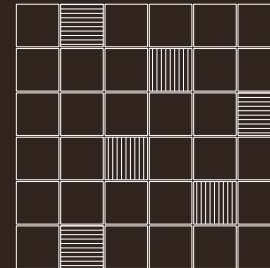

50%

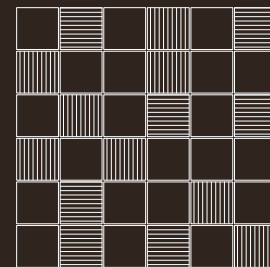

100%

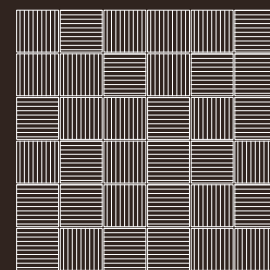

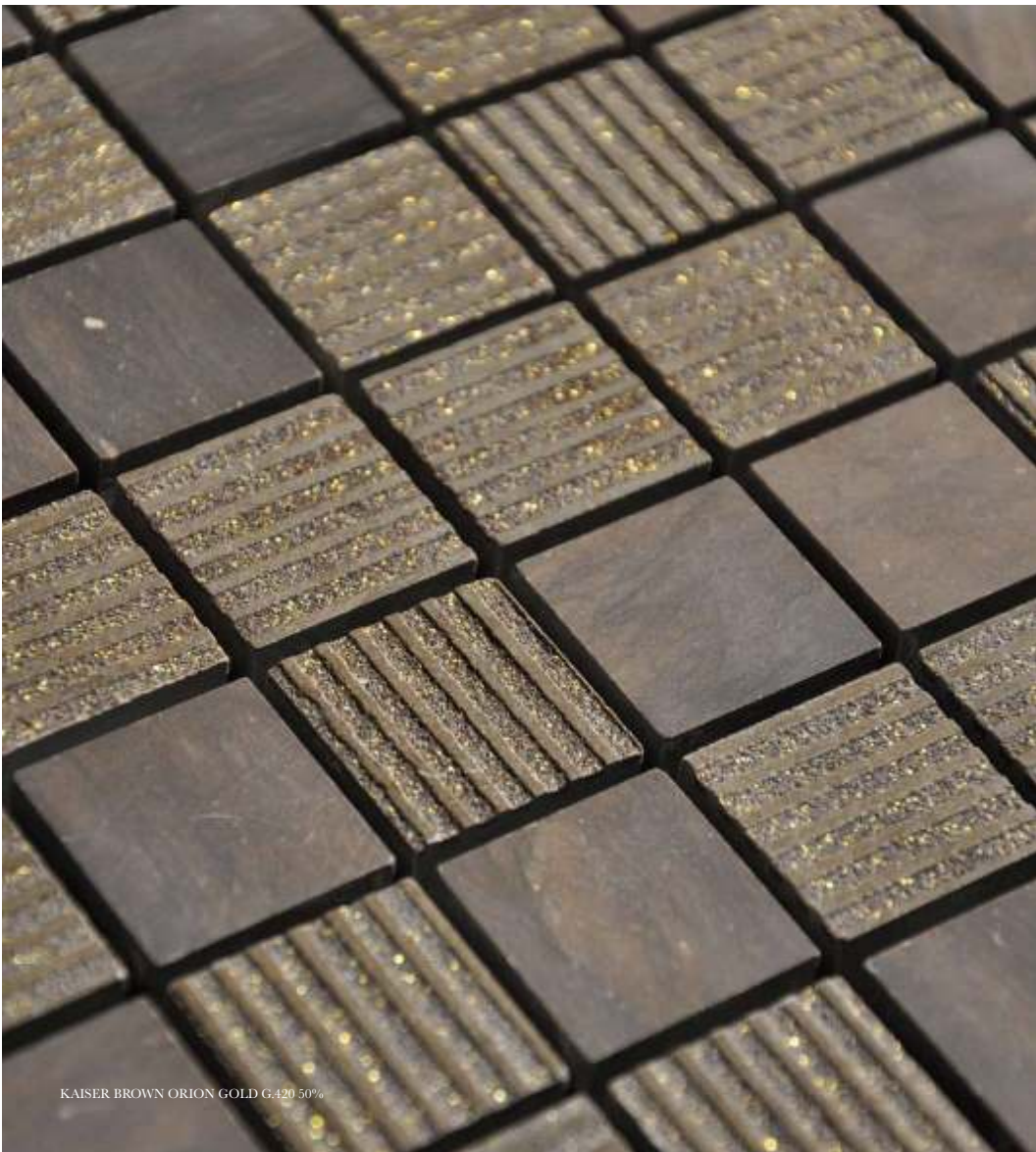

KAISER BROWN ORION GOLD G.420 50%

ORION MATRIX 2,5

20%

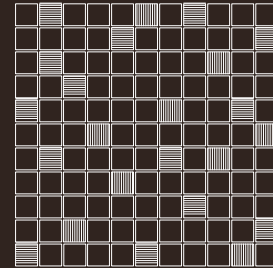

50%

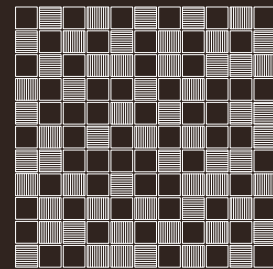

100%

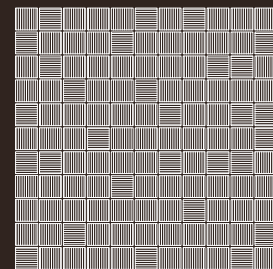



ORION GOLD G.420 100%

ORION CANETÈ

20%

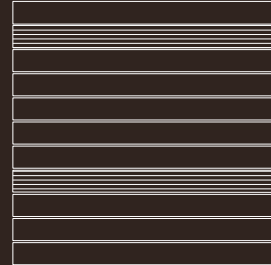

50%

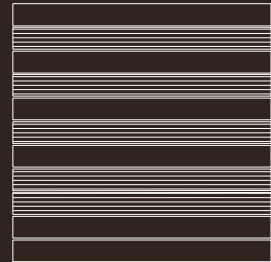

100%

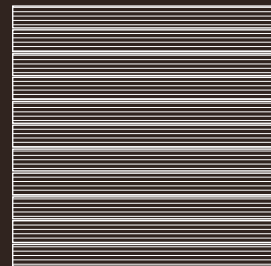



ORION SPIGATO



ICE
S.220



S.280



S.240

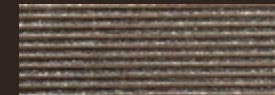

FIRE
G.300

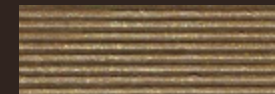

G.420



G.360

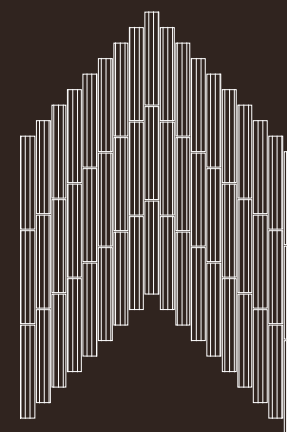



NERO ORION GOLD G.360

ORION PIED DE POULE

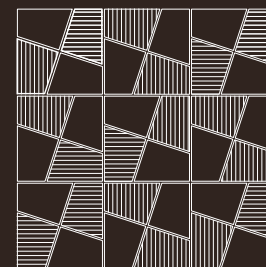

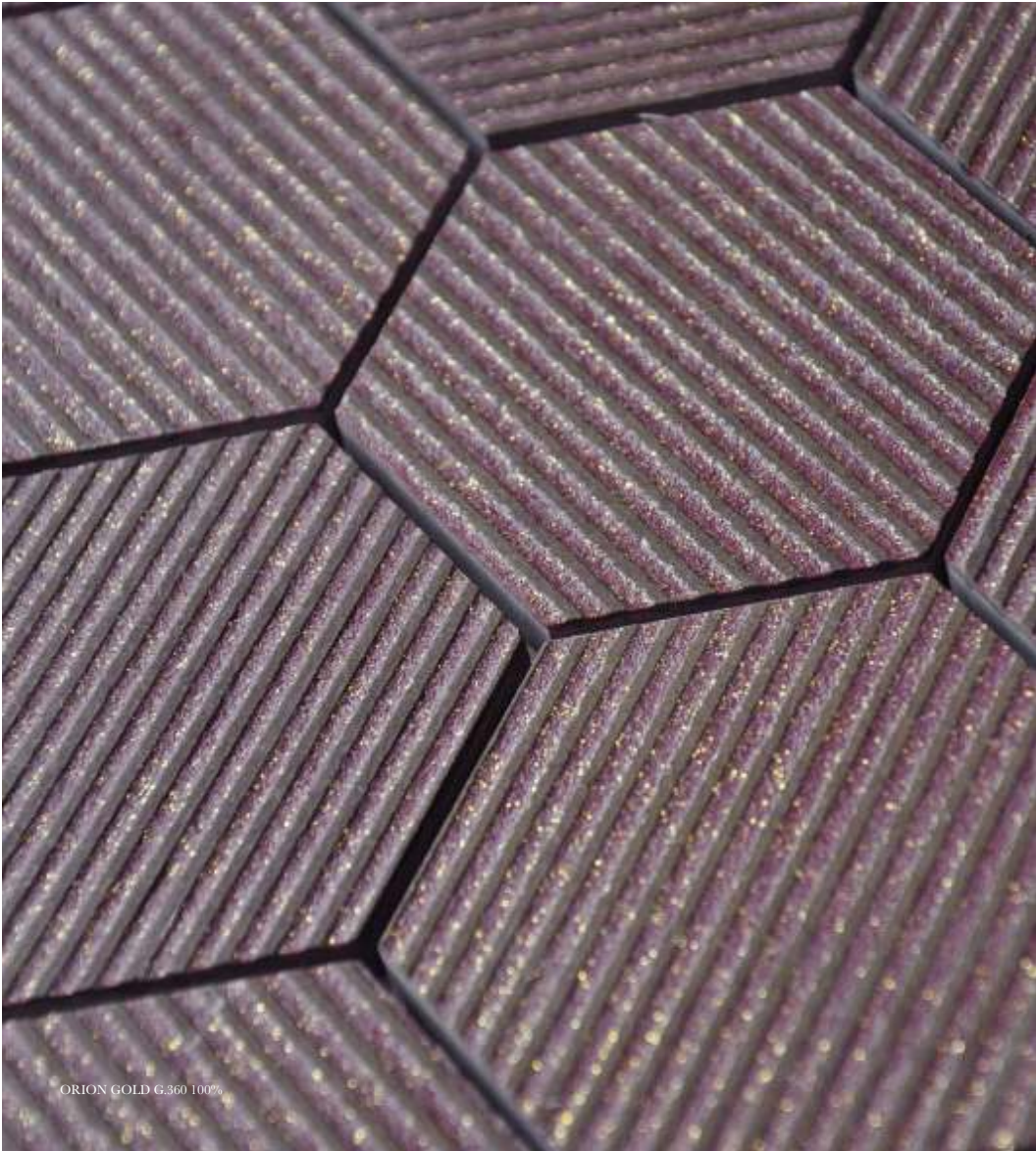

ORION NIDO D'APE

20%

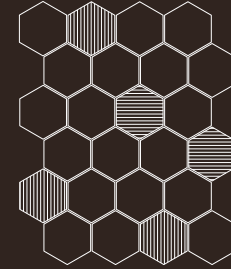

50%

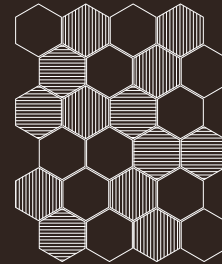

100%

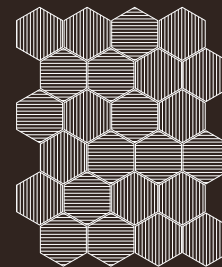



MIDA'sTONE



MIDA'sTONE |

“MIDA'sTone” indaga la preziosa essenza della decorazione, valorizzando la perizia artigianale e la cura del dettaglio, in grado di rendere qualsiasi lastra di pietra un'opera d'arte. Le pietre, incise, vestite di lamine dorate o argentate e sfumate manualmente con maestria come filigrane pregiate; tessuti lapidei e decori unici in grado di vestire con ricercatezza ed eleganza la casa.

“MIDA'sTone” researches the precious decorations, enhancing handcraft and care of details able to give any piece the true masterpiece's value. The crafted stone dressed of gold or silver layer, thanks also to the manual shade are true unique pieces which make today the timeless value of handcraft hand work for unique decors able to dress your home as precious textile.

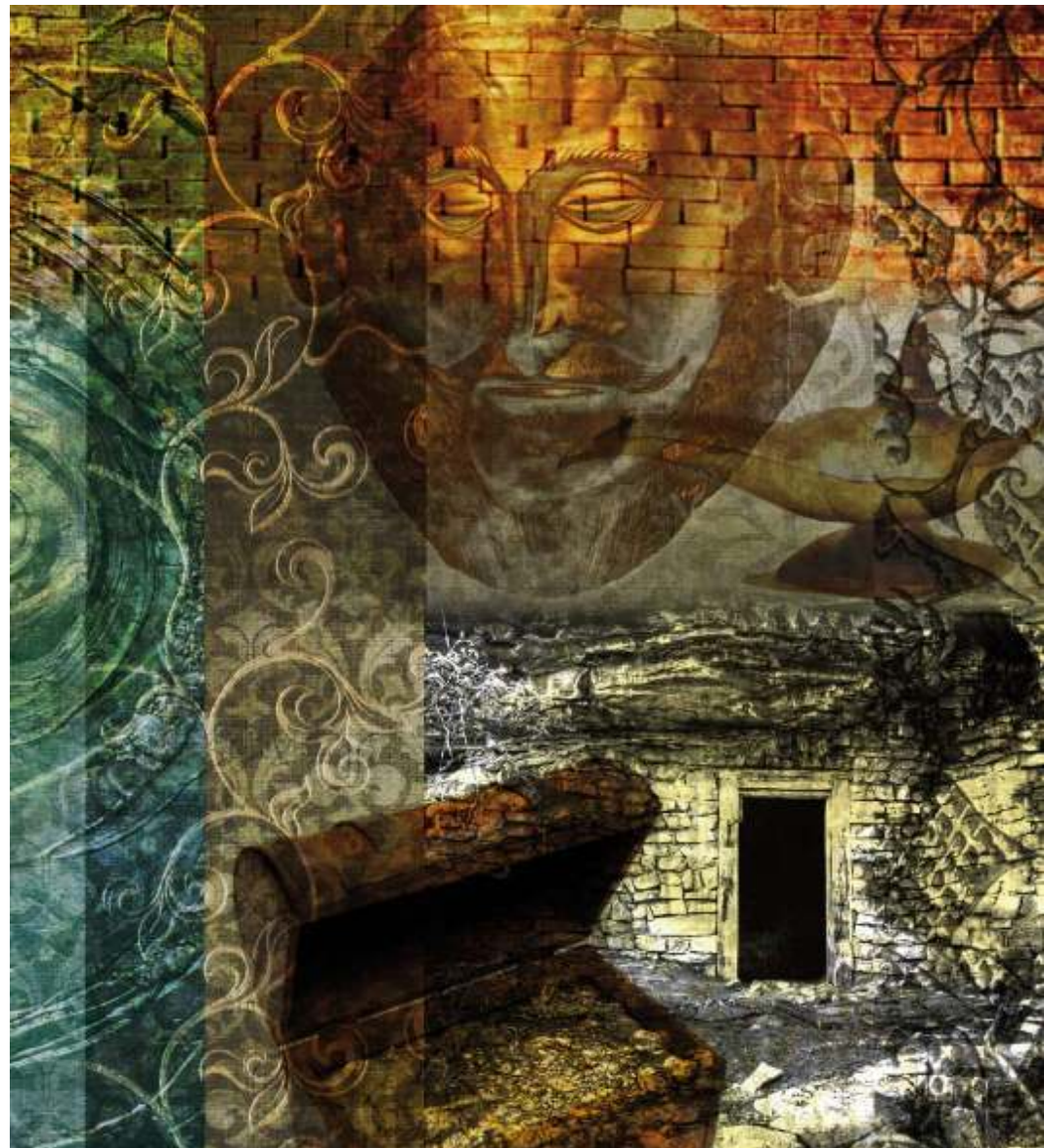



BAROCCO YUNA DARK FONDO INCISO ARGENTO 29,3x59,3cm
LIBERTY YUNA DARK FONDO INCISO ORO 29,3x29,3cm

*The crafted stone dressed of
gold or silver layer*



RINASCIMENTO BIANCO FONDO INCISO ORO 29,8x29,8cm
GOTICO NERO FONDO INCISO ARGENTO 29,8x29,8cm

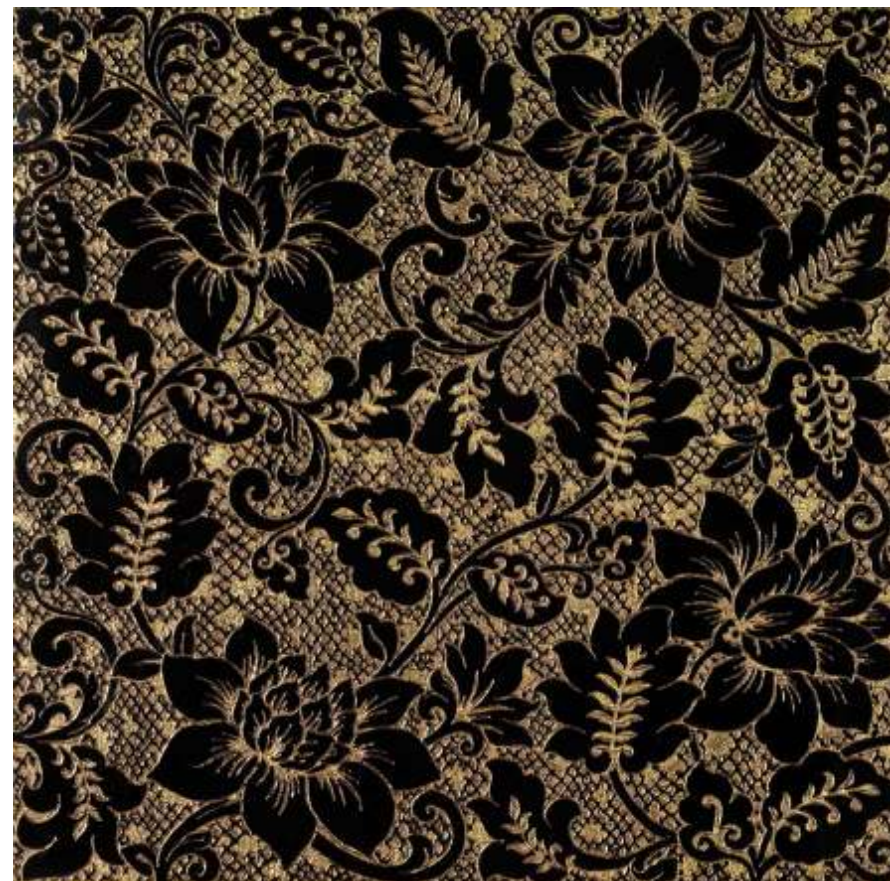

RINASCIMENTO NERO FONDO INCISO ORO 29.8x29.8cm



BAROCCO NERO DECORO INCISO ORO 29,8x29,8cm





306

307

GOTICO YUNA DARK DECORO INCISO ARGENTO 25 x 29 cm



LIBERTY BIANCONE DECORO INCISO ORO 29.8x29.8cm







RINASCIMENTO BIANCONE FONDO INCISO ORO 29,8x29,8cm





316

317

LIBERTY NERO FONDO INCISO NATURAL 29,3x29,8cm





MIDA'sTONE |

Gotico

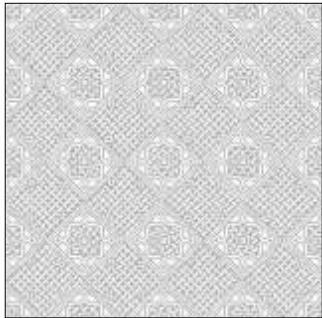

Rinascimento



Liberty

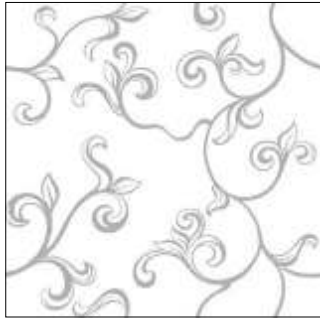

Barocco





MIDA'sTONE | Gotico

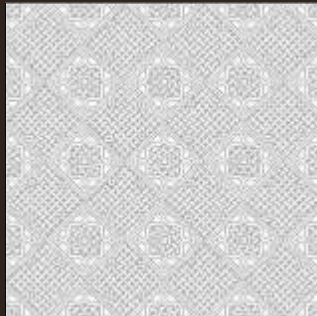

Size
29.8x29.8x1cm

Wall and floor material

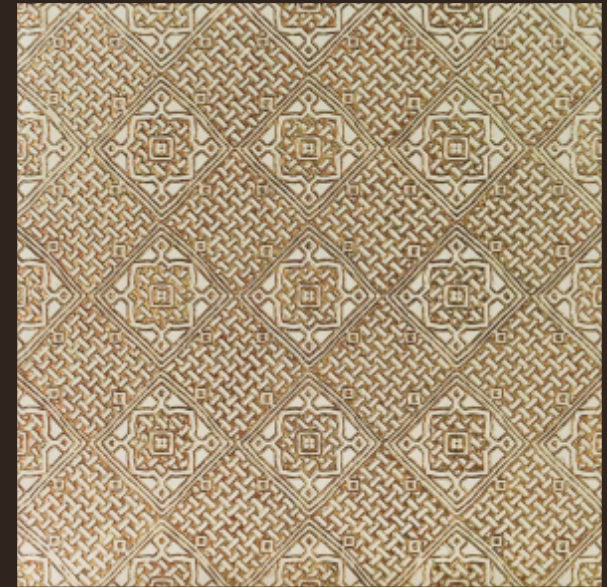

BIANCONE FONDO INCISO ORO



BIANCONE FONDO INCISO ORO

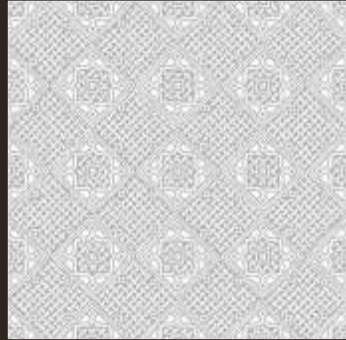
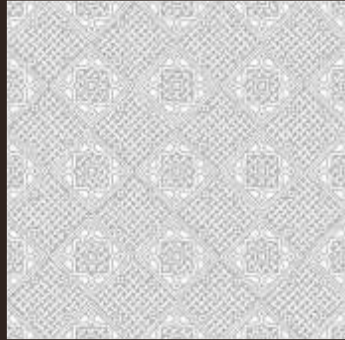
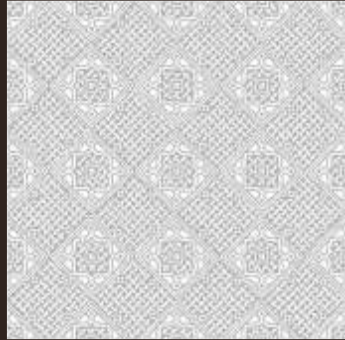

NERO FONDO INCISO ARGENTO



NERO FONDO INCISO ORO

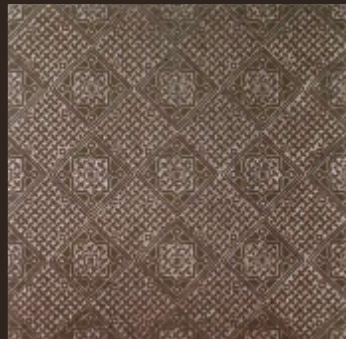
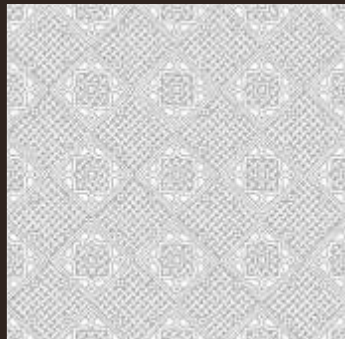
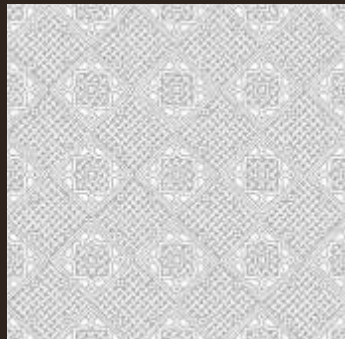

YUNA DARK FONDO INCISO ARGENTO

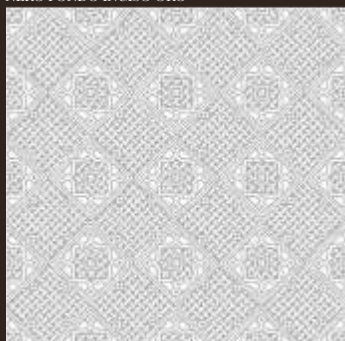
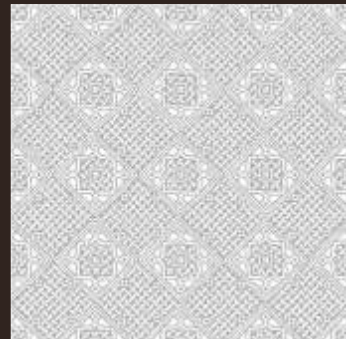

YUNA DARK FONDO INCISO NATURAL

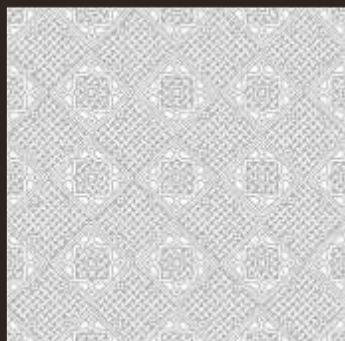

BIANCONE FONDO INCISO NATURAL



NERO FONDO INCISO NATURAL



MIDA'sTONE | Rinascimento



Size
29.8x29.8x1cm

Wall and floor material



BIANCONE FONDO INCISO ARGENTO



NERO FONDO INCISO ORO



BIANCONE FONDO INCISO NATURAL



NERO FONDO INCISO ARGENTO



YUNA DARK FONDO INCISO ARGENTO



BIANCONE FONDO INCISO ORO



TRAVERTINO FONDO INCISO NATURAL



ROSSO PERSIA FONDO INCISO NATURAL



BIANCONE FONDO INCISO ARGENTO



NERO FONDO INCISO NATURAL



YUNA DARK FONDO INCISO NATURAL



TRAVERTINO FONDO INCISO ORO



MIDA'sTONE | Liberty

Decoro inciso



Size
29.8x29.8x1cm

Wall and floor material

Fondo inciso



Size
29.8x29.8x1cm

Wall material

Liberty fondo inciso natural può essere usato anche a pavimento.

Liberty fondo inciso natural can be also used for flooring.



LIBERTY NERO DECORO INCISO ORO



LIBERTY NERO FONDO INCISO ORO



TRAVERTINO DECORO INCISO ORO



YUNA DARK DECORO INCISO ORO



TRAVERTINO DECORO INCISO NATURAL



BIANCONE DECORO INCISO NATURAL



BIANCONE DECORO INCISO ARGENTO



BIANCONE DECORO INCISO ORO



ROSSO PERSIA DECORO INCISO ORO



YUNA DARK DECORO INCISO NATURAL



YUNA DARK DECORO INCISO ARGENTO



TRAVERTINO DECORO INCISO ARGENTO



NERO DECORO INCISO ORO



ROSSO PERSIA DECORO INCISO NATURAL



NERO DECORO INCISO NATURAL



NERO DECORO INCISO ARGENTO





BIANCONE FONDO INCISO NATURAL



BIANCONE FONDO INCISO ARGENTO

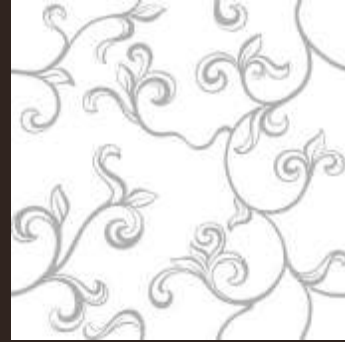

YUNA DARK FONDO INCISO ORO



ROSSO PERSIA FONDO INCISO ARGENTO



NERO FONDO INCISO NATURAL

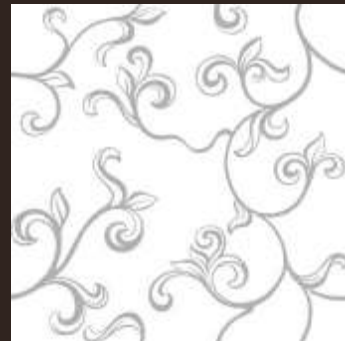
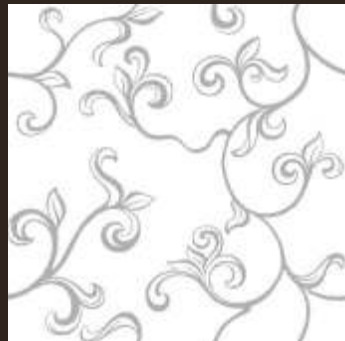

TRAVERTINO FONDO INCISO ORO



ROSSO PERSIA FONDO INCISO ORO



YUNA DARK FONDO INCISO ARGENTO



NERO FONDO INCISO ARGENTO

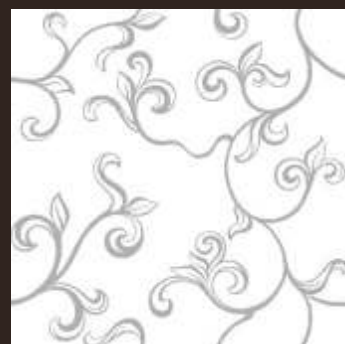

NERO FONDO INCISO ORO





MIDA'sTONE | Barocco

Decoro inciso



Size
29.8x59.8x1cm

Wall material

Fondo inciso



Size
29.8x59.8x1cm

Wall material



BAROCCO NERO DECORO INCISO ORO



BAROCCO NERO FONDO INCISO ORO



NERO DECORO INCISO ORO



YUNA DARK DECORO INCISO NATURAL



ROSSO PERSIA DECORO INCISO ARGENTO



NERO DECORO INCISO ARGENTO



ROSSO PERSIA DECORO INCISO ORO



NERO DECORO INCISO NATURAL



TRAVERTINO DECORO INCISO NATURAL



YUNA DARK DECORO INCISO ORO



BIANCONE DECORO INCISO ORO



TRAVERTINO DECORO INCISO ORO



YUNA DARK FONDO INCISO ARGENTO



NERO FONDO INCISO NATURAL



BIANCONE FONDO INCISO ORO



YUNA DARK FONDO INCISO ORO



NERO FONDO INCISO ARGENTO



NERO FONDO INCISO ORO



TRAVERTINO FONDO INCISO ARGENTO



BIANCONE FONDO INCISO ARGENTO



YUNA DARK FONDO INCISO ARGENTO



NERO FONDO INCISO ARGENTO



BIANCONE FONDO INCISO ARGENTO



NERO FONDO INCISO ARGENTO



YUNA DARK FONDO INCISO ARGENTO



BIANCONE FONDO INCISO ARGENTO



STONES

STONES



BOTTICINO



SOPHIA BEIGE



CREMASTONE



GIALLO PALMAS

Sizes
29.8x29.8cm
29.8x59.8cm
40x40cm
40x80cm
60x60cm
60x120cm
80x80cm

Per altri formati vedi listino.
For other sizes see our price list.



STONES



TRAVERTINO CHIARO



TRAVERTINO NOCE



ROSSO PERSIA

Sizes
29.8x29.8cm
29.8x59.8cm
40x40cm
40x80cm
60x60cm
60x120cm
80x80cm

Per altri formati vedi listino.
For other sizes see our price list.



STONES



ARDESIA NERA



ARDESIA VERDE



ARDESIA BORDEAUX



CORTEN

Sizes
29.8x29.8cm
29.8x59.8cm
40x40cm
40x80cm
60x60cm
60x120cm
80x80cm

Per altri formati vedi listino.
For other sizes see our price list.

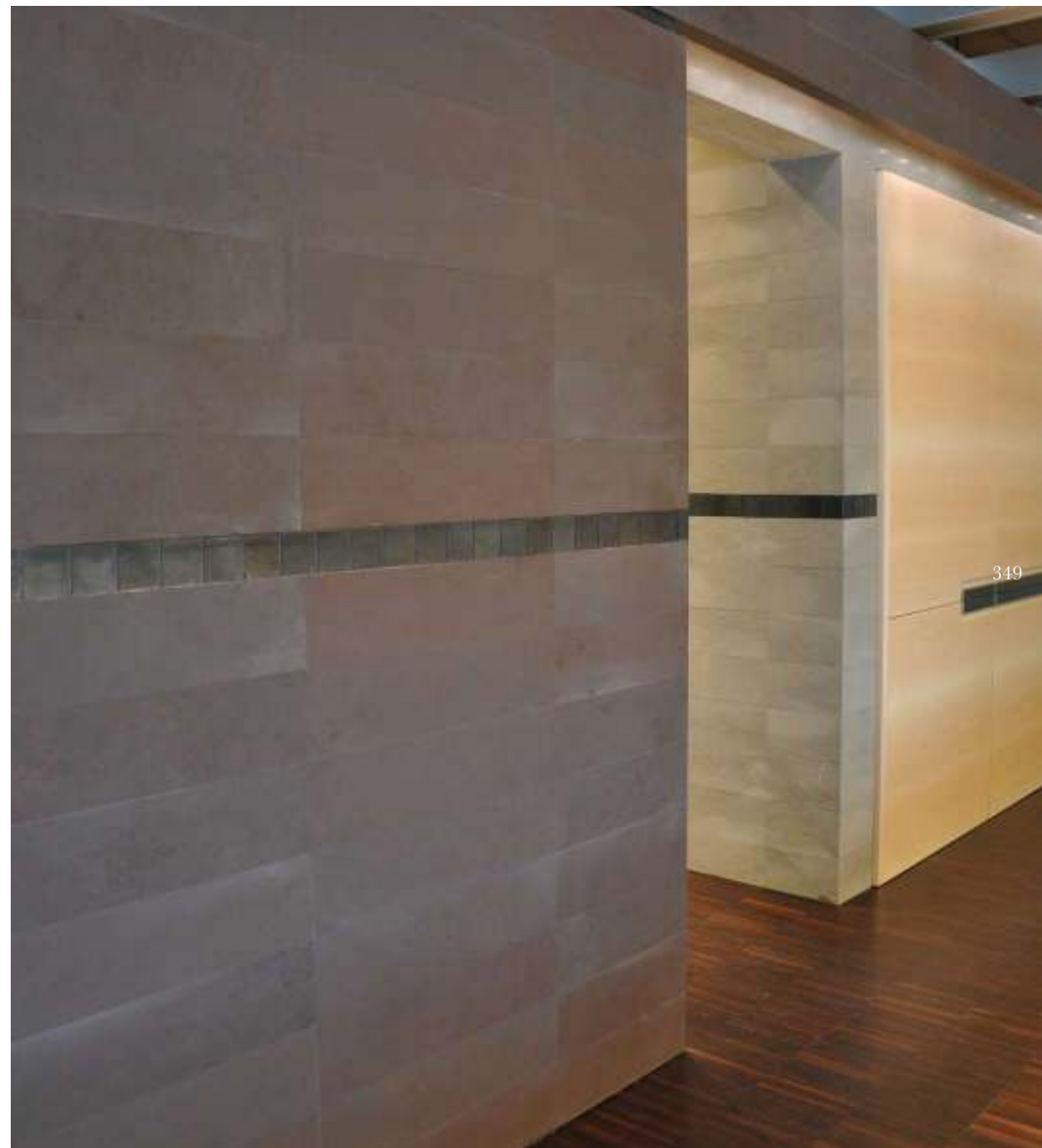

STONES



YUNA DARK



KAISER BROWN



ROOTS

Sizes
29.8x29.8cm
29.8x59.8cm
40x40cm
40x80cm
60x60cm
60x120cm
80x80cm

Per altri formati vedi listino.
For other sizes see our price list.



STONES



BIANCO CARRARA



BIANCONE



GRIGIO BARDIGLIO



NERO

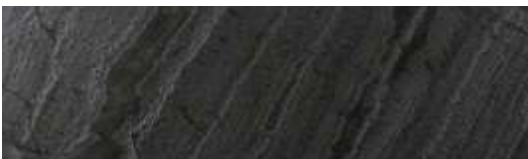

RIO BLACK

Sizes
29.8x29.8cm
29.8x59.8cm
40x40cm
40x80cm
60x60cm
60x120cm
80x80cm

Per altri formati vedi listino.
For other sizes see our price list.

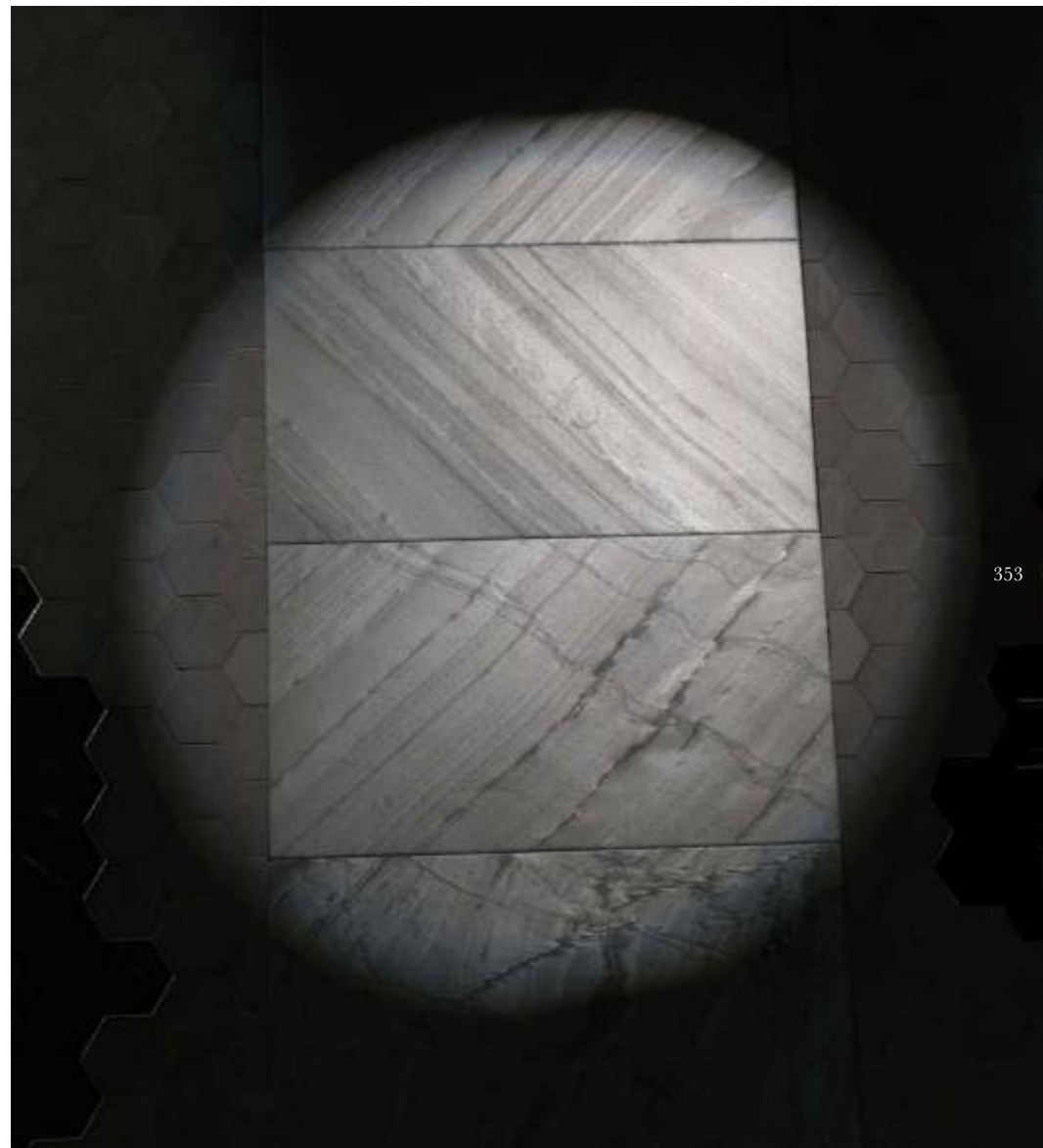



SKINS

SKINS



MATT



HAMMER



HAMMER BRUSH



SKINS

COMB



COMB BRUSH





AQUAM



AQUAM |

La nuova collezione di arredo bagno che unisce tradizione e tecnologia accostando per la prima volta pietra e Corian®. La forza della pietra, la sua storia millenaria e le sue sfumature vengono per la prima volta accostate alla superficie versatile, moderna e matt del corian, un connubio ardito per la linea di acquei scultura Benetti.

The new bathroom interior collection matching tradition and technology, combining for the first time stone with Corian®. An innovative line combining for the first time stones millennial history, strength and nuances with corian versatile and modern-looking surface.

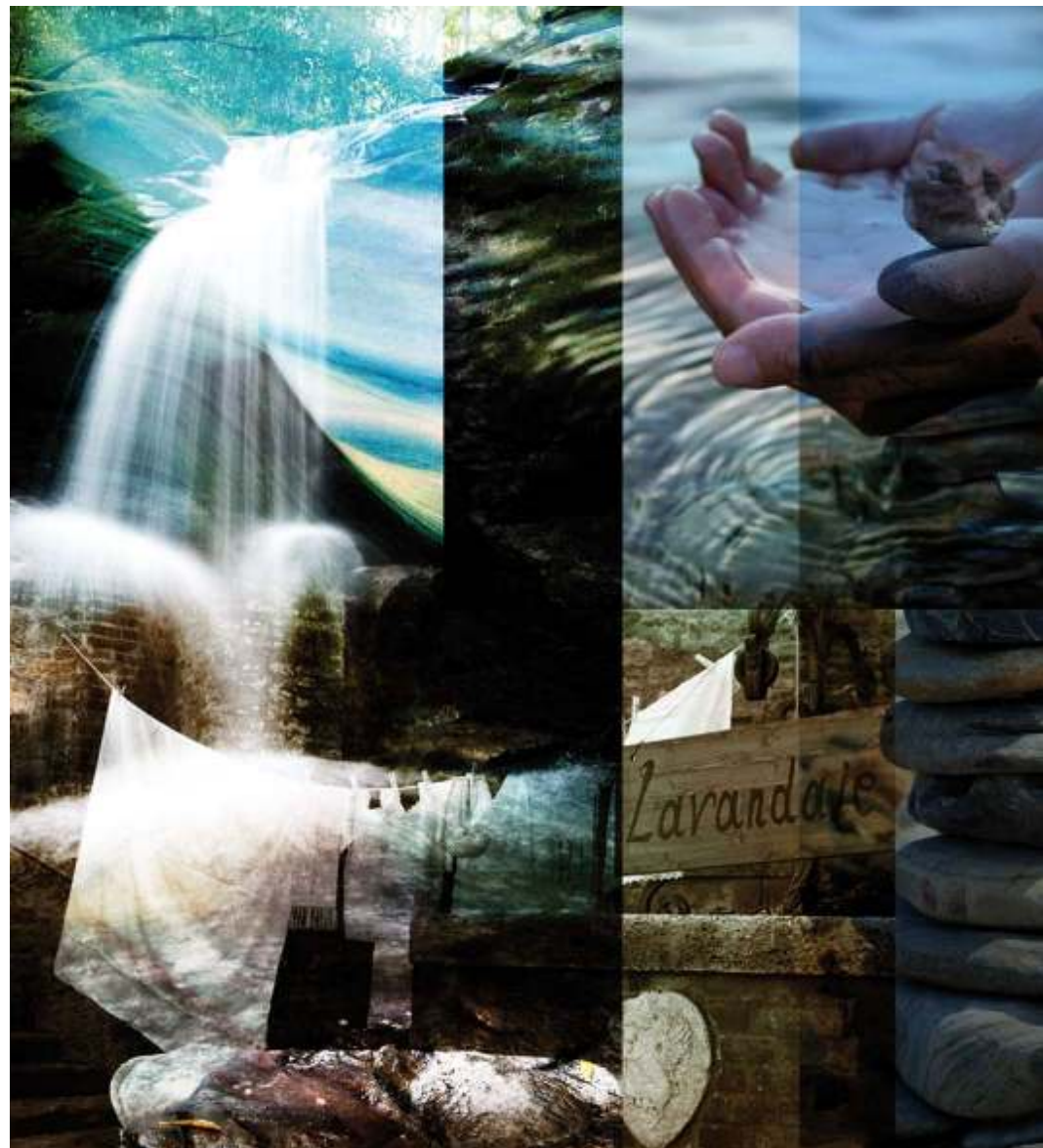

Nourish your innermost soul



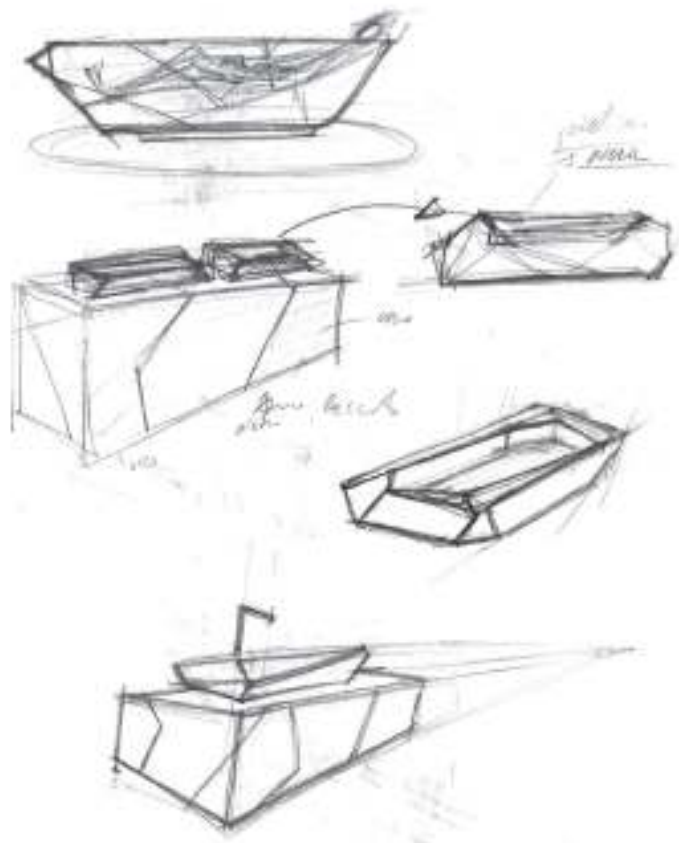

Lavabo JEWEL



Lavabo RING CORIAN TOWER



Lavabo RING CORIAN BASIN



Lavabo SPRINGWATER TOWER





Vasca in mosaico YUNA DARK GROS GRAIN



Lavabo RING STONE BASIN YUNA DARK



Lavabo RING STONE TOWER YUNA DARK



water shapes stone drop by drop



Lavabo JEWEL

AQUAM



Lavabo

JEWEL



379

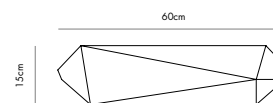
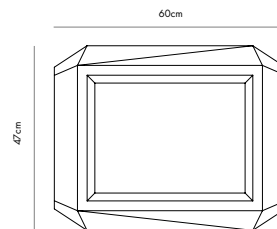

Lavabo in Corian®.
Colore GLACIER WHITE



AQUAM

Lavabo

LIKE YOU TOWER

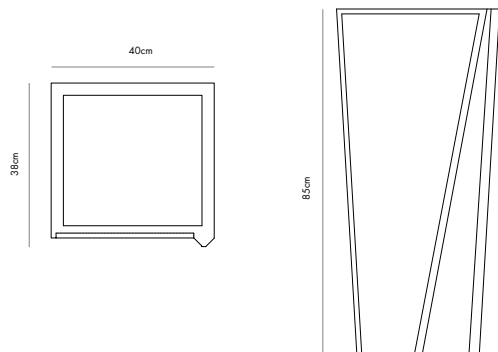

È il primo lavabo in Corian® e pietra pensato per essere personalizzabile secondo i propri gusti, ripropo-
nendo, perchè no, una frase o una poesia... perchè l'ambiente in cui vivi possa veramente essere come te.

Like you is the first sink made of corian and stone, which can be personalized according to your taste. How about carving your favourite words or poem on it? Let your house reflect your thoughts and way of being.

380



Lavabo in Corian®.
Colore GLACIER WHITE

Lastra in pietra



AQUAM

Lavabo

LIKE YOU BASIN

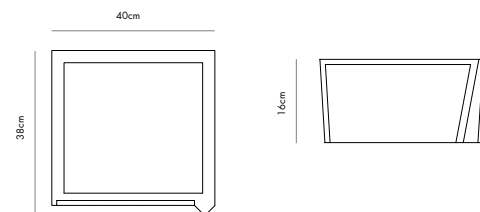

È il primo lavabo in Corian® e pietra pensato per essere personalizzabile secondo i propri gusti, ripropo-
nendo, perchè no, una frase o una poesia... perchè l'ambiente in cui vivi possa veramente essere come te.

Like you is the first sink made of corian and stone, which can be personalized according to your taste. How about carving your favourite words or poem on it? Let your house reflect your thoughts and way of being.

381

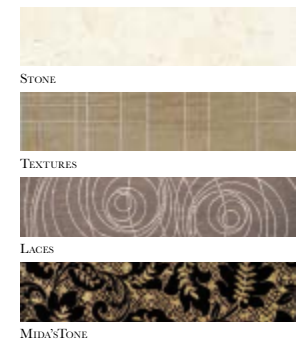

Lavabo in Corian®.
Colore GLACIER WHITE

Lastra in pietra

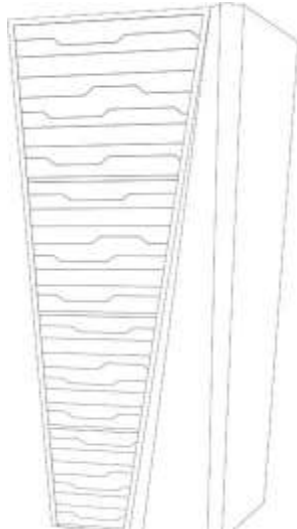
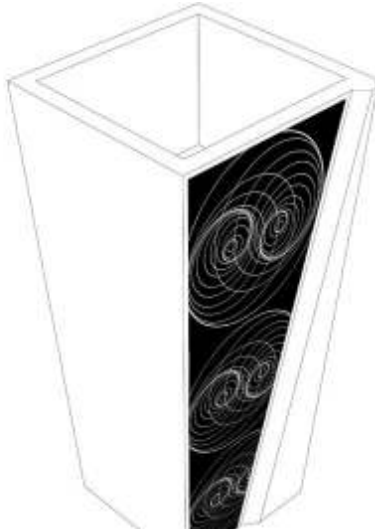
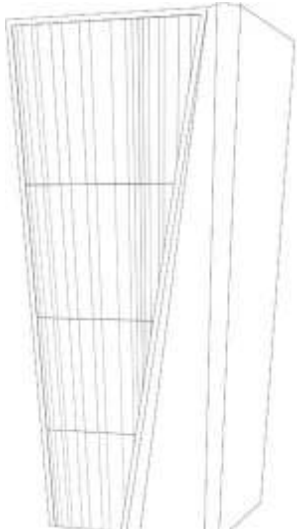
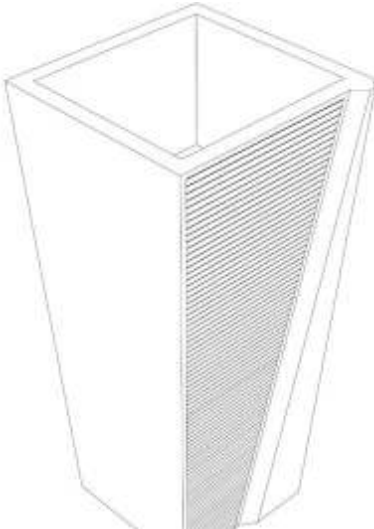
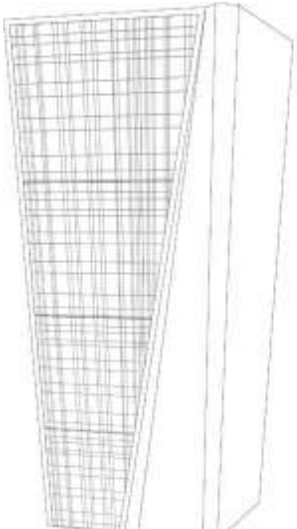
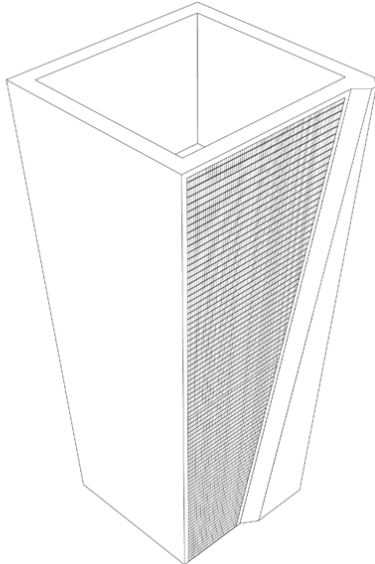
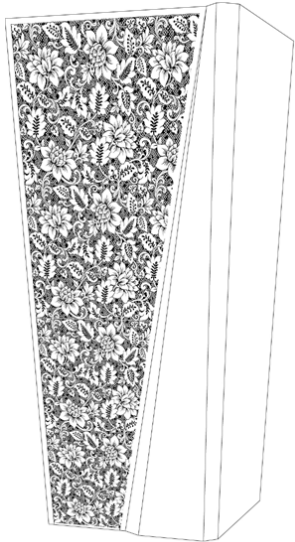
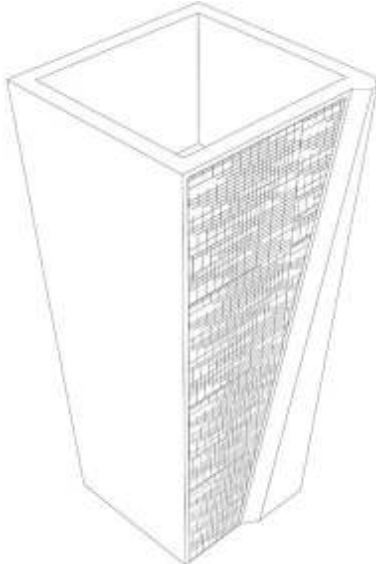
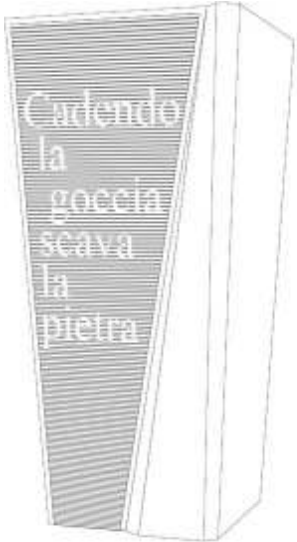
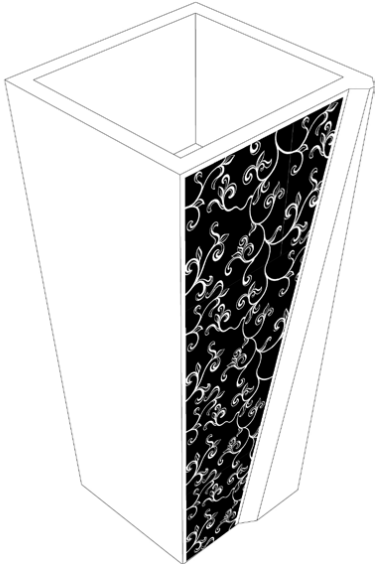



AQUAM

Lavabo

RING STONE TOWER

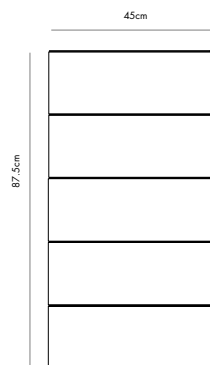
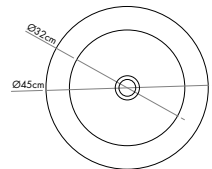

AQUAM

Lavabo

RING STONE BASIN

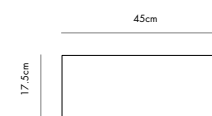
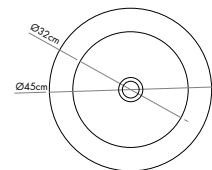

385

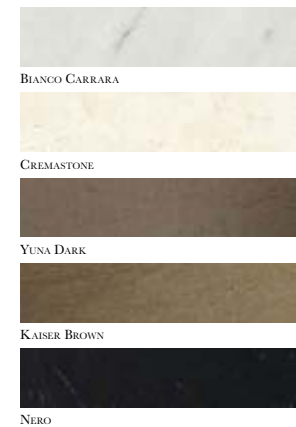

BIANCO CARRARA

CREMASTONE

YUNA DARK

KAISER BROWN

NERO

384



BIANCO CARRARA

CREMASTONE

YUNA DARK

KAISER BROWN

NERO



AQUAM

Lavabo

RING CORIAN TOWER

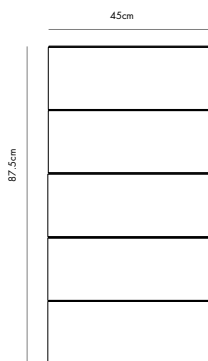
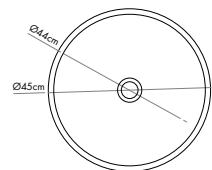

386



BIANCO CARRARA



CREMASTONE



YUNA DARK



KAISER BROWN



NERO

Catino in Corian®.
Colore GLACIER WHITE

Colonna in pietra



AQUAM

Lavabo

RING CORIAN BASIN

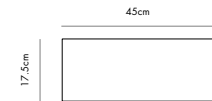
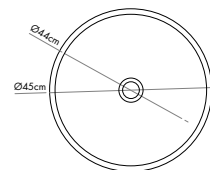

387

Lavabo in Corian®.
Colore GLACIER WHITE



AQUAM

Lavabo

SPRINGWATER TOWER

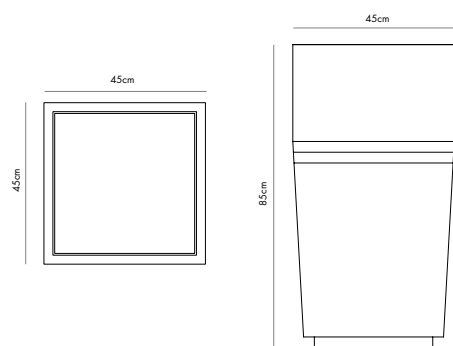

AQUAM

Lavabo

SPRINGWATER BASIN

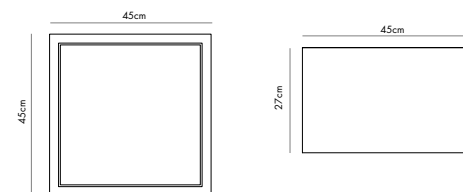

388



BIANCO CARRARA



CREMASTONE



YUNA DARK



KAISER BROWN



NERO

389



BIANCO CARRARA



CREMASTONE



YUNA DARK



KAISER BROWN



NERO



AQUAM

Lavabo

BIG ROCK

Avvalendosi della grande abilità della natura nello scolpire rocce morbide e tondeggianti, che opportunamente fresate diventano lavabi a colonna o da appoggio nasce la linea rock. Veri e propri pezzi unici, nati da rocce tornite dal tempo per elementi d'arredo inimitabili ed esclusivi. Nulla è più bello della semplicità e dell'essenza stessa della natura.

Benetti's Rock line takes advantage of nature's exceptional ability to carve smooth rounded rocks, which by proper milling become unique basins, exclusive fittings for your bathroom.
There is nothing more true and pleasant than nature's own genuineness and pure essence



AQUAM

Lavabo

ROCK

Avvalendosi della grande abilità della natura nello scolpire rocce morbide e tondeggianti, che opportunamente fresate diventano lavabi a colonna o da appoggio nasce la linea rock. Veri e propri pezzi unici, nati da rocce tornite dal tempo per elementi d'arredo inimitabili ed esclusivi. Nulla è più bello della semplicità e dell'essenza stessa della natura.

Benetti's Rock line takes advantage of nature's exceptional ability to carve smooth rounded rocks, which by proper milling become unique basins, exclusive fittings for your bathroom.
There is nothing more true and pleasant than nature's own genuineness and pure essence





AQUAM

Lavabo

PYRAMID

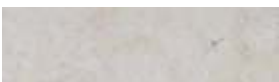
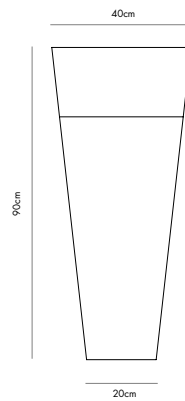
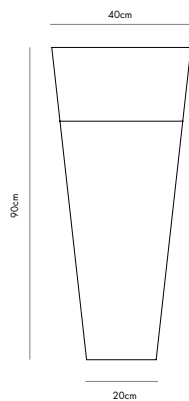
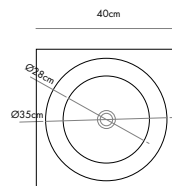

TRAVERTINO CHIARO



TRAVERTINO NOCE



AQUAM

Lavabo

CONE

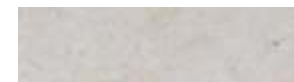
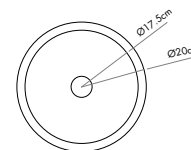

TRAVERTINO CHIARO



TRAVERTINO NOCE



AQUAM

Lavabo

CATINO

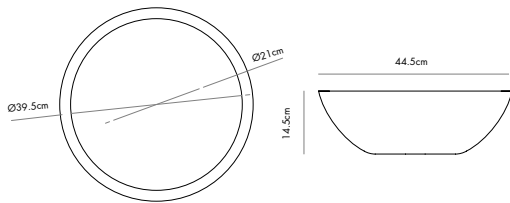

TRAVERTINO CHIARO

TRAVERTINO NOCE

- * LE VISIONI DELL'ARCHITETTO
- * VIRUS DESIGN
- * SECRET DESIGN
- * LEGGERE IL DESIGN
- * CARA CASA
- * DESIGNLAB
- * CORALOB

LA PIETRA FILOSOFALE

La casa come luogo appetitivo
 spaziale, polifunzionale
 sensoriale, moderna,
 tecnologica, culturale
 riflessiva, meditativa,
 etica, naturale
 artistica,
 spirituale
 cosa teatrale,
 ecocritica, egocentrica

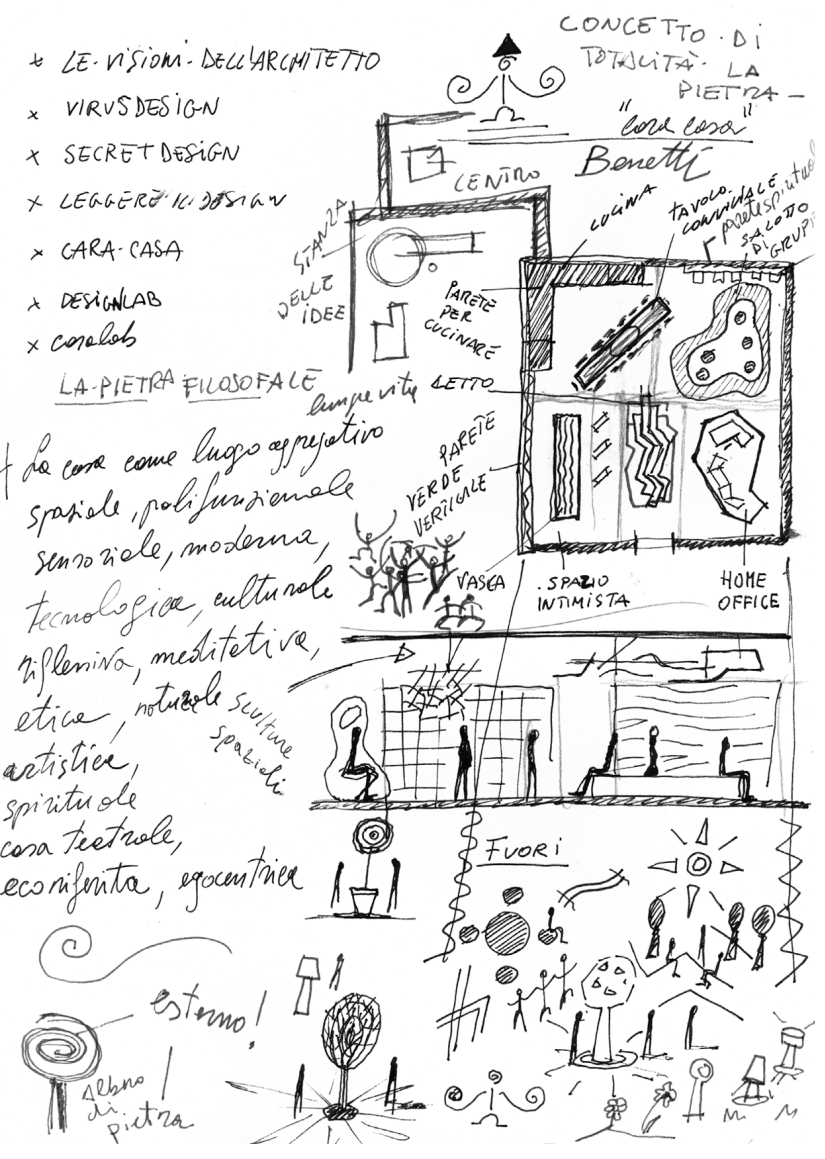



AQUAM



Piatto Doccia

TRAPEZIUM

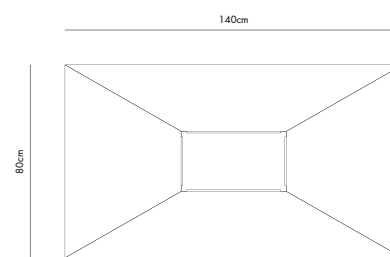

STONE + GRIGLIA INOX

2cm

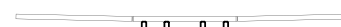

6,5cm

397



BIANCO CARRARA



CREMASTONE



YUNA DARK



KAISER BROWN



NERO



AQUAM

Piatto Doccia

DISCUS



398



BIANCO CARRARA



CREMASTONE



YUNA DARK



KAISER BROWN



NERO

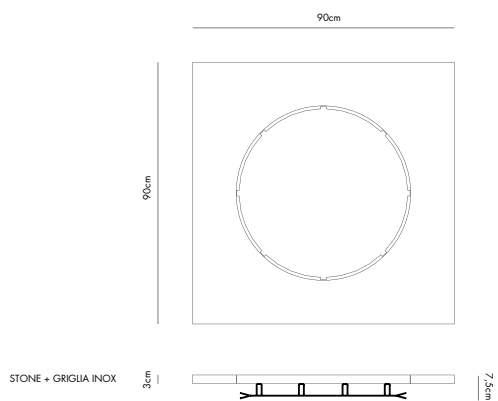

AQUAM

Piatto Doccia

LINEA



399



BIANCO CARRARA



CREMASTONE



YUNA DARK



KAISER BROWN



NERO

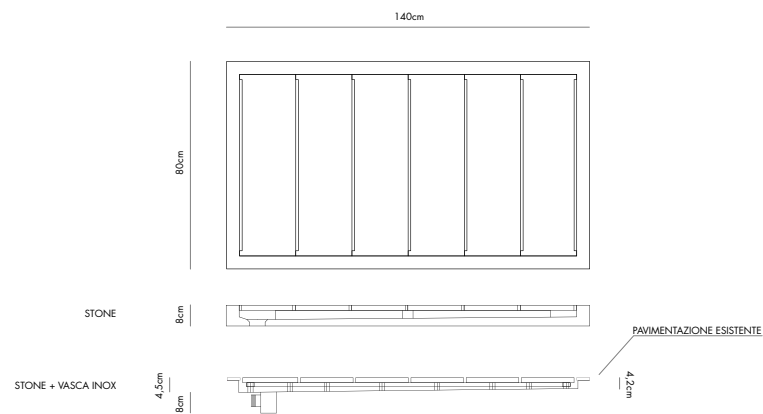



AQUAM

Piatto Doccia

PLANUM 145



AQUAM

Piatto Doccia

PLANUM 90



400



BIANCO CARRARA



CREMASTONE



YUNA DARK



KAISER BROWN

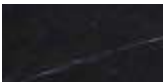

NERO

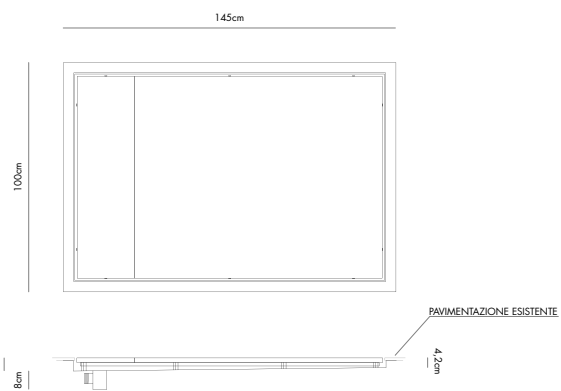

401



BIANCO CARRARA



CREMASTONE



YUNA DARK



KAISER BROWN

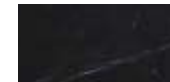

NERO

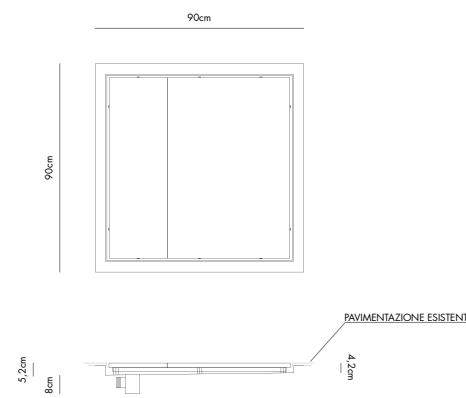

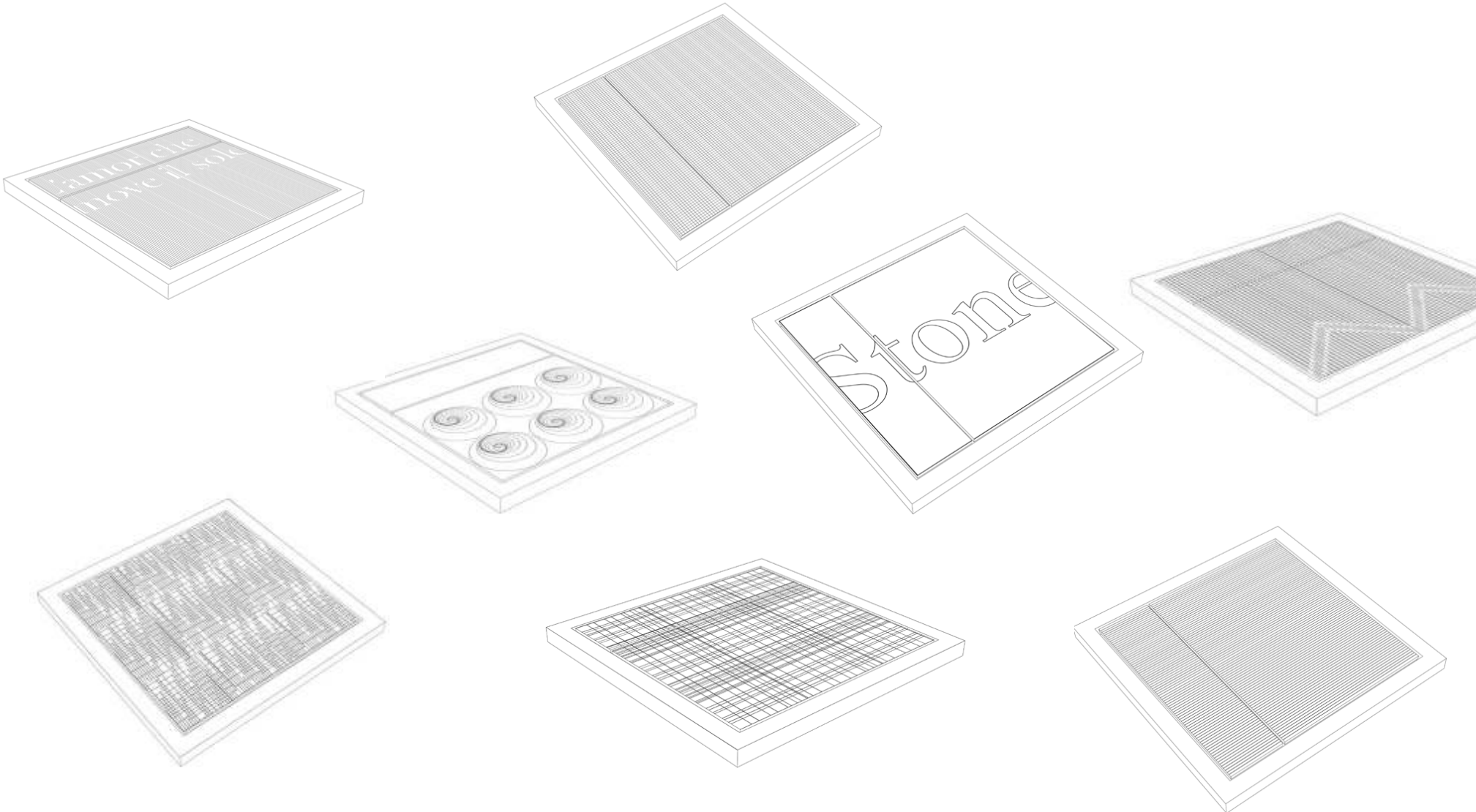



MONOLIGHT



MONOLIGHT |

Vere e proprie sculture da esterno, originate da forme pure ed organiche. Una collezione di elementi per l'arredo urbano che prende nuovo vigore al calare della sera, quando i led ad incasso generano coni di luce che esaltano i volumi ed il verde circostante.

Real outside sculptures originating from organic and pure shapes. A collection of elements for the new urban design that takes effect after sunset, when the leds generate light cones enhancing volumes and natural surroundings.



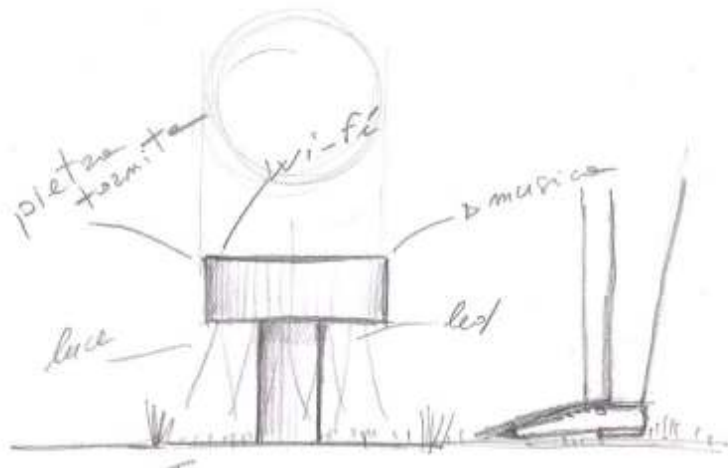

LAMPADA OUTDOOR AMANITA



LAMPADA OUTDOOR ABATNUIT

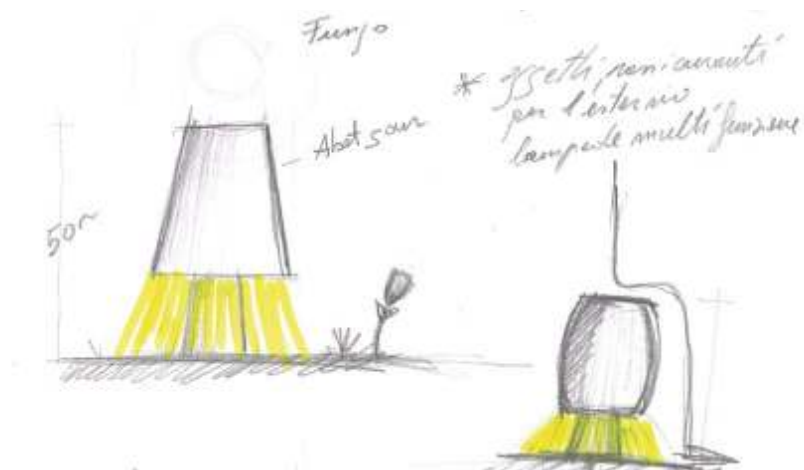



MONOLIGHT

Lampada Outdoor

AMANITA

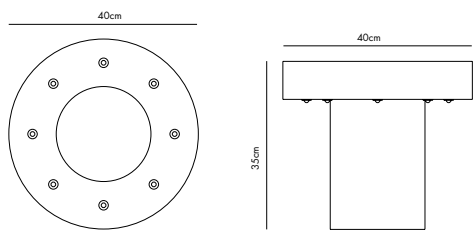

412



MONOLIGHT

Lampada Outdoor

ABATNUIT

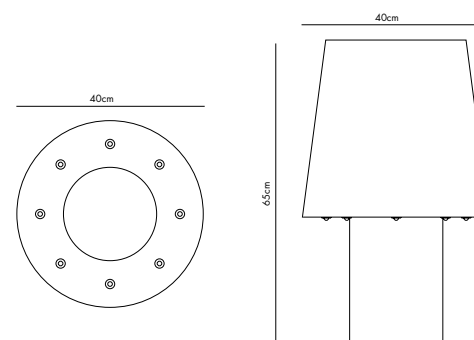

413

ART DIRECTION
Studio Rotella

COORDINAMENTO
Livia Balossini
Alessandra Albini

GRAPHIC DESIGN
Alessio Mauro

VISUAL DESIGN

Alessandra Albini
19-49-75-85-91-121-143-171-253-297-361-407

Aleksandar Mihov
304-307-310-314-317

FOTOGRAFIA

Fabio Rotella
16-34-37-169-172-214-250-254-255-276-277

Cristina Fiorentini
20-21-22-23-78-79-81-94-95-96-97-146-159-160-161
162-304-307-310-314-317-349-353-371-373-396

Livia Balossini
24-25-50-51-52-86-87-141-150-174-175-176-177-178-179
182-183-186-187-188-189-192-194-196-198-200-202-204
206-210-212-220-222-224-226-228-230-232-234-236-238
240-242-243-244-245-246-247-248-249-265-294

Art Direction Studio Rotella - Milano
www.studiorotella.com

L'irripetibilità delle sfumature, e le unicità di venatura sono caratteristiche di pregio distintive della pietra naturale, per questo i toni rappresentati sono da considerarsi puramente indicativi.

Unique shades and veins are a valuable feature of our natural stones. Thus, the nuances here showed are not to be considered representative.

